

Protective Devices Maintenance as it Applies to the Arc/Flash Hazard

Presented by

Dennis K. Neitzel, CPE

Director



A DIVISION OF MEGGER

Training Institute – Dallas, Texas

Introduction

- ☞ **Key component of the Flash Hazard Analysis:**
 - **Protective device clearing time.**
 - ◆ **Primarily circuit breakers and relays.**
- ☞ **Fuses do not have operating mechanisms**
- ☞ **Primary focus is maintenance issues**

Introduction

- ☞ **Molded case and low-voltage power circuit breakers:**
 - Will generally clear a fault condition in 3 to 8 cycles.
 - To be conservative a clearing time of 8 cycles should be used.
- ☞ **Older medium-voltage circuit breakers:**
 - Will clear a fault in around 8 cycles
 - Newer ones clear in 3 to 5 cycles.

Introduction

☞ Protective relays:

- Add approximately 3 to 4 cycles to the clearing time of the medium circuit breaker.

☞ Maintenance and testing not performed:

- Extended clearing times could occur
- Unintentional time delay
- Results of flash hazard analysis could be affected

Introduction

☞ Maintenance and testing

- Accomplished in accordance with the manufacturer's instructions, or
- NETA *“Maintenance Testing Specifications for Electrical Power Distribution Equipment and Systems”* 2001 Edition.

Molded-Case Circuit Breakers

- ☞ **Maintenance on molded-case circuit breakers is limited to:**
 - Proper mechanical mounting
 - Electrical connections
 - Periodic manual operation
- ☞ **Lighting, appliance, and power panel circuit breakers**
 - Have riveted frames
 - Are not designed to be opened

Molded-Case Circuit Breakers

- ☞ **All other MCCB's that are UL approved:**
 - Factory-sealed to prevent access to calibrated elements.
- ☞ **An unbroken seal indicates:**
 - Mechanism has not been tampered with
 - Should function as specified by UL.
- ☞ **A broken seal voids the UL listing and the manufacturers' warranty of the device:**
 - Integrity of the device would be questionable.

Molded-Case Circuit Breakers

- ☞ **MCCB's, other than the riveted frame types:**
 - Permitted to be reconditioned and returned to the manufacturer's original condition.
- ☞ **To conform to the manufacturer's original design:**
 - Must be reconditioned according to recognized standards.
 - ◆ Professional Electrical Apparatus Recyclers League (PEARL)

Molded-Case Circuit Breakers

- ☞ **Circuit breakers are often forgotten.**
- ☞ **Breakers supplying power for years:**
 - **Several things that can go wrong.**
 - ◆ **Circuit breakers can fail to open due to a burned out trip coil, or**
 - ◆ **Fail because the mechanism is frozen due to dirt, dried lubricant, or corrosion.**

Molded-Case Circuit Breakers

- ☞ **Overcurrent devices can fail due to:**
 - Inactivity, or
 - A burned out electronic component.
- ☞ **Problems occur when a breaker fails to open under fault conditions.**
 - Can result in fires, damage to equipment or injuries to personnel.

Molded-Case Circuit Breakers

☞ **A circuit breaker fails due to:**

- Minimum maintenance was not performed, or
- Performed improperly.

☞ **Recommendation:**

- If an MCCB has not been operated within as little as six months time:
 - ◆ Removed from service, and
 - ◆ Manually exercised several times.

Molded-Case Circuit Breakers

- ☞ **Manually exercising helps:**
 - **Keep the contacts clean due to their wiping action**
 - **Ensures that the operating mechanism moves freely**
 - **Does not operate the tripping mechanism**

Molded-Case Circuit Breakers

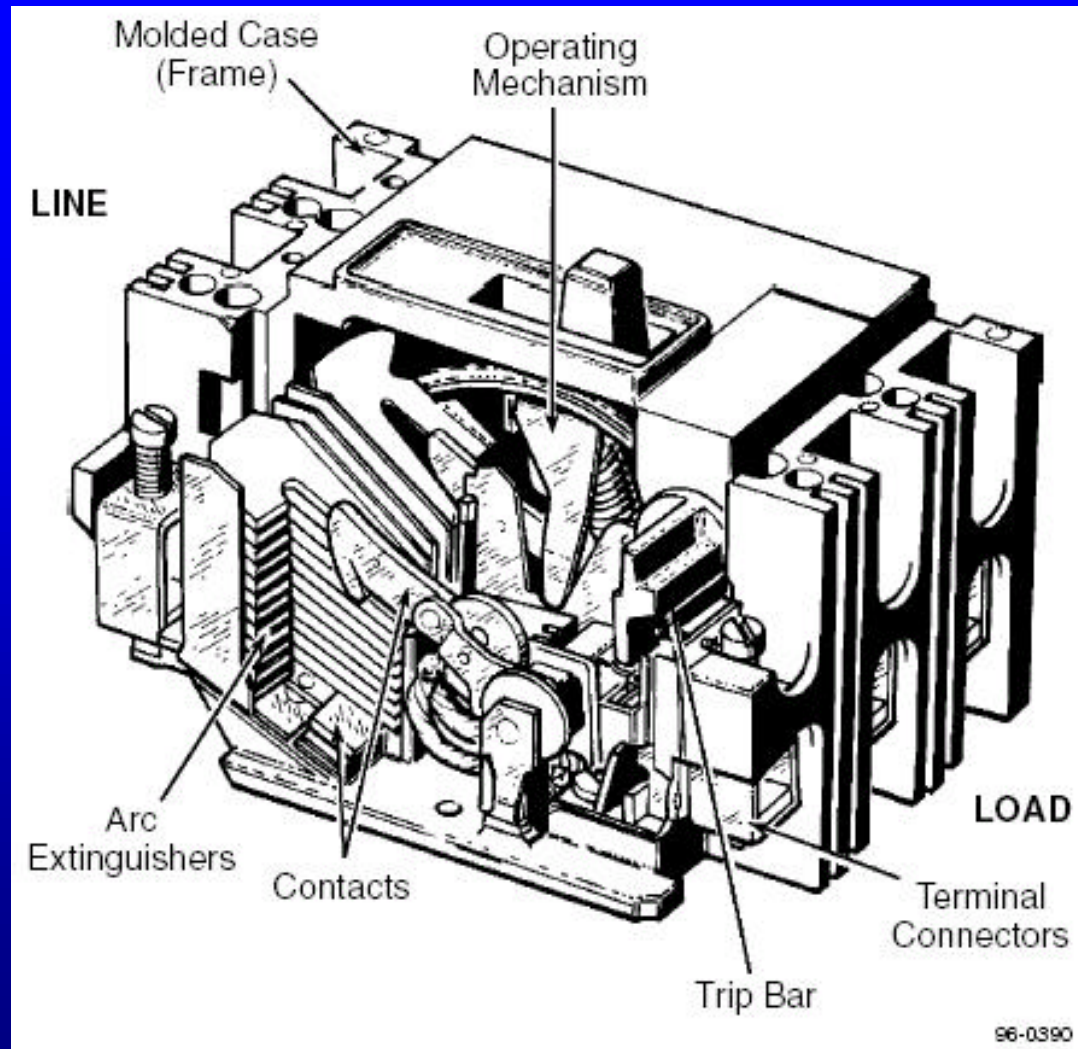

Molded-Case Circuit Breakers

- ☞ **Proper exercise of all breaker mechanisms:**
 - Remove the breaker from service and test the overcurrent and short-circuit tripping capabilities
- ☞ **A stiff or sticky mechanism can cause:**
 - An unintentional time delay, and therefore
 - Increase the arc/flash incident energy level.

Molded-Case Circuit Breakers

☞ Another consideration, addressed by OSHA:

1910.334(b)(2) Reclosing circuits after protective device operation “After a circuit is deenergized by a circuit protective device, the circuit may NOT be manually reenergized until it has been determined that the equipment and circuit can be safely reenergized. The repetitive manual reclosing of circuit breakers or reenergizing circuits through replaced fuses is prohibited.”

Molded-Case Circuit Breakers

- **Employee is at risk if the short circuit still exists.**
- **The past practice of resetting a circuit breaker one, two, or three times before investigating is no longer allowed.**
- **This previous practice has caused numerous burn injuries that resulted from the explosion of electrical equipment.**

Molded-Case Circuit Breakers

- **Circuit breakers, circuits, and equipment, must be tested and inspected by a qualified person.**
- **Melted arc chutes will not interrupt fault currents.**
- **If the breaker cannot interrupt a second fault, it will fail.**
 - **May destroy enclosure and create a hazard for personnel.**

Molded-Case Circuit Breakers

☞ In an EC&M article by NEMA, Jan. 1995 :

“After a high level fault has occurred in equipment that is properly rated and installed, it is not always clear to investigating electricians what damage has occurred inside encased equipment.”

Low-Voltage Power Circuit Breakers

- **Several studies have shown:**
 - **Circuit breakers, which were not maintained within a 5-year period, have a 50% failure rate.**
- **Maintenance will generally consist of keeping them clean and properly lubricated.**
- **Frequency of maintenance will depend to some extent on cleanliness of area.**

Low-Voltage Power Circuit Breakers

- **General inspection and lubrication is recommended at least once per year.**
- **Some make this recommendation after the first six months of service.**

Low-Voltage Power Circuit Breakers

- ☞ **If the breaker remains open or closed for a long period of time:**
 - Open and close the breaker several times
 - Exercise under load conditions (hazard-remote operation)
- ☞ **Environmental conditions play a major role.**
- ☞ **More frequent inspections and maintenance may be required if:**
 - Severe load conditions exist
 - Inspection reveals heavy accumulations of dirt, moisture, or other foreign matter

Low-Voltage Power Circuit Breakers

- ☞ **Mechanical failure would include:**
 - **Unintentional time delay in the tripping operation due to:**
 - ◆ **Dry, dirty or corroded pivot points**
 - ◆ **Hardened or sticky lubricant**
- ☞ **The manufacturer's instructions must be followed in order to minimize the risk of any unintentional time delay.**

Low-Voltage Power Circuit Breakers

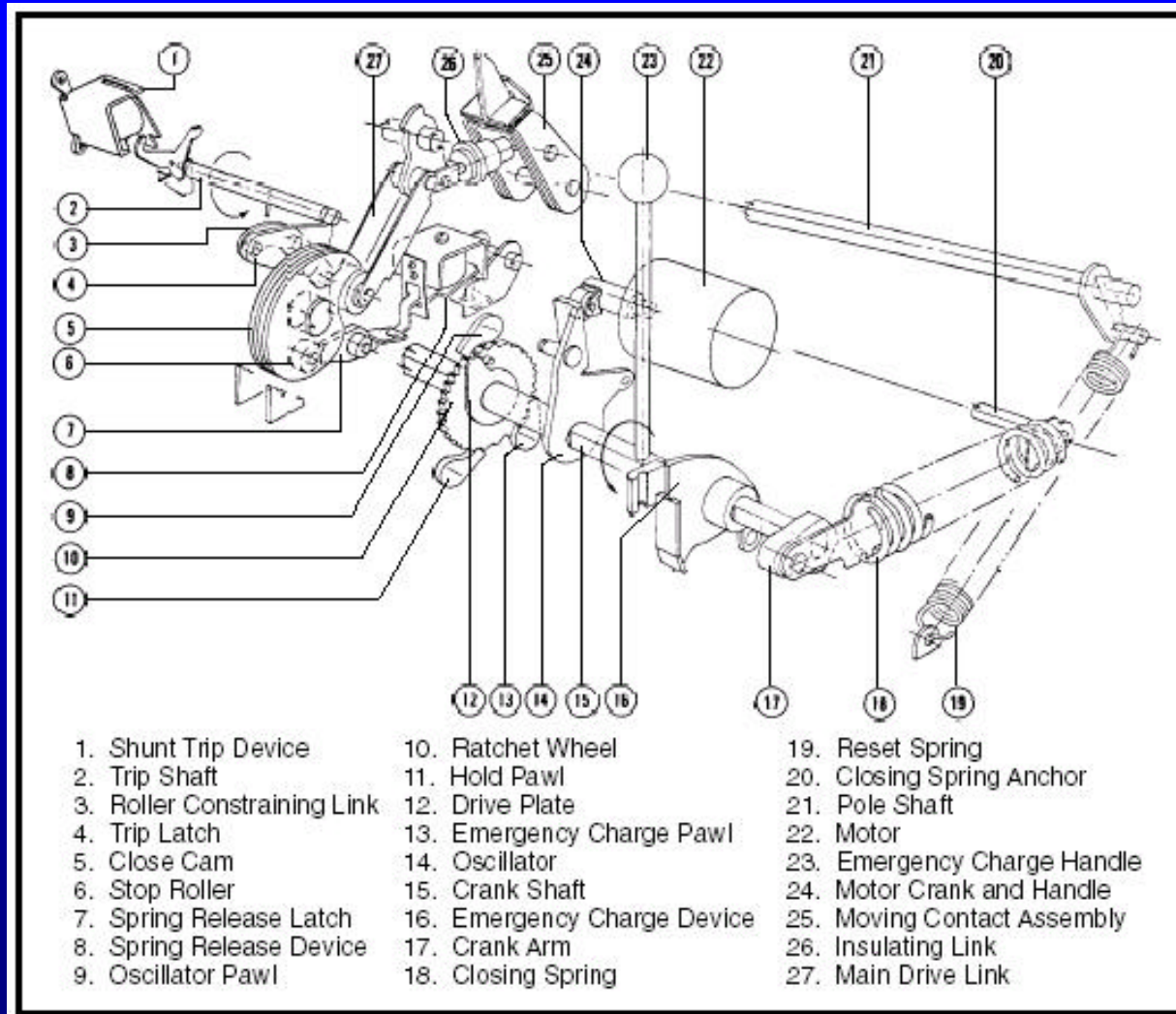

Medium-Voltage Power Circuit Breakers

- **Most requirements the same as low-voltage power circuit breakers.**
- **Breakers should be removed from service and inspected at least once per year.**
- **Always follow the manufacturer's instructions.**

Medium-Voltage Power Circuit Breakers

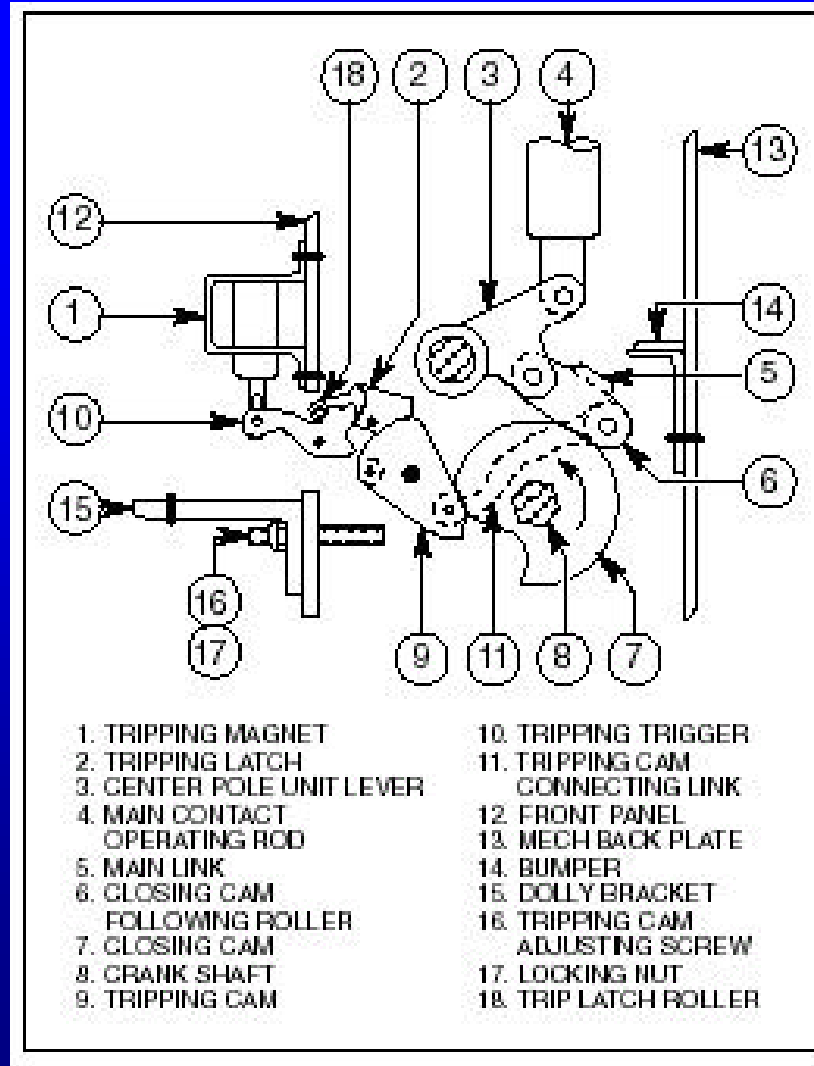

Medium-Voltage Power Circuit Breakers

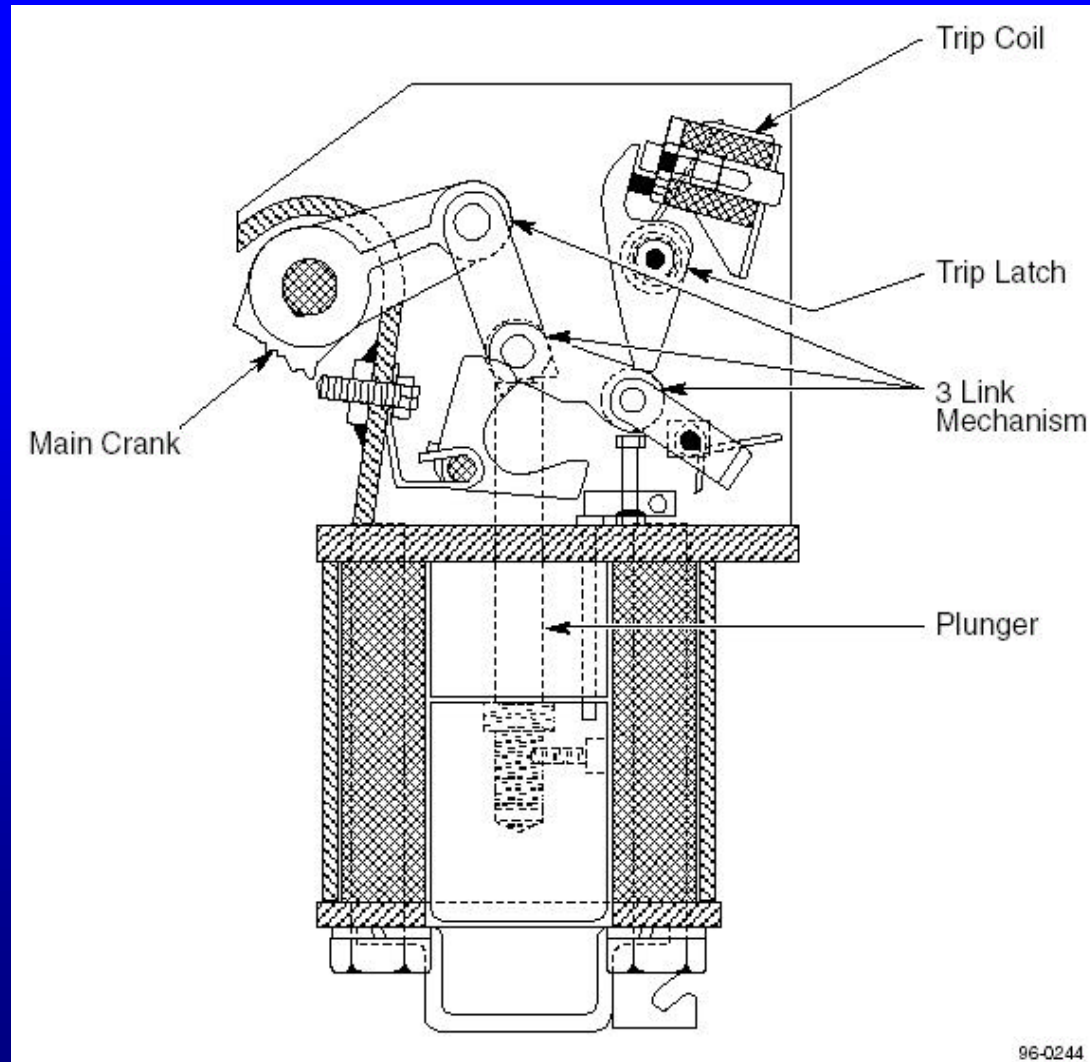

96-0244

Protective Relays

- **Relays monitor complex power circuit conditions, such as:**
 - Current and voltage magnitudes
 - Phase angle relationships
 - Direction of power flow
 - Frequency
- **When a short circuit (or fault) is detected:**
 - Relay responds and closes its contacts
 - The abnormal portion of the circuit is deenergized via the circuit breaker

Protective Relays

- **The ultimate goal of protective relaying is to disconnect a faulty system element as quickly as possible.**
- **Sensitivity and selectivity are essential to ensure that the proper circuit breakers are tripped at the proper speed to:**
 - **Clear the fault**
 - **Minimize damage to equipment**
 - **Reduce the hazards to personnel**

Protective Relays

- ☞ **Several things may happen to prevent primary relaying from disconnecting a power system fault:**
 - **Current or voltage supplies to the relays are incorrect.**
 - **DC tripping voltage supply is low or absent.**
 - **Protective relay malfunctions.**
 - **Tripping circuit or breaker mechanism hangs up.**

Protective Relays

- Each element of the system has *zones of protection* surrounding the element.
- A fault within the given zone should cause the tripping of all circuit breakers within that zone and no tripping of breakers outside that zone.
- If faults occur in the overlap region, several breakers respond and isolate the sections from the power system.

Protective Relays

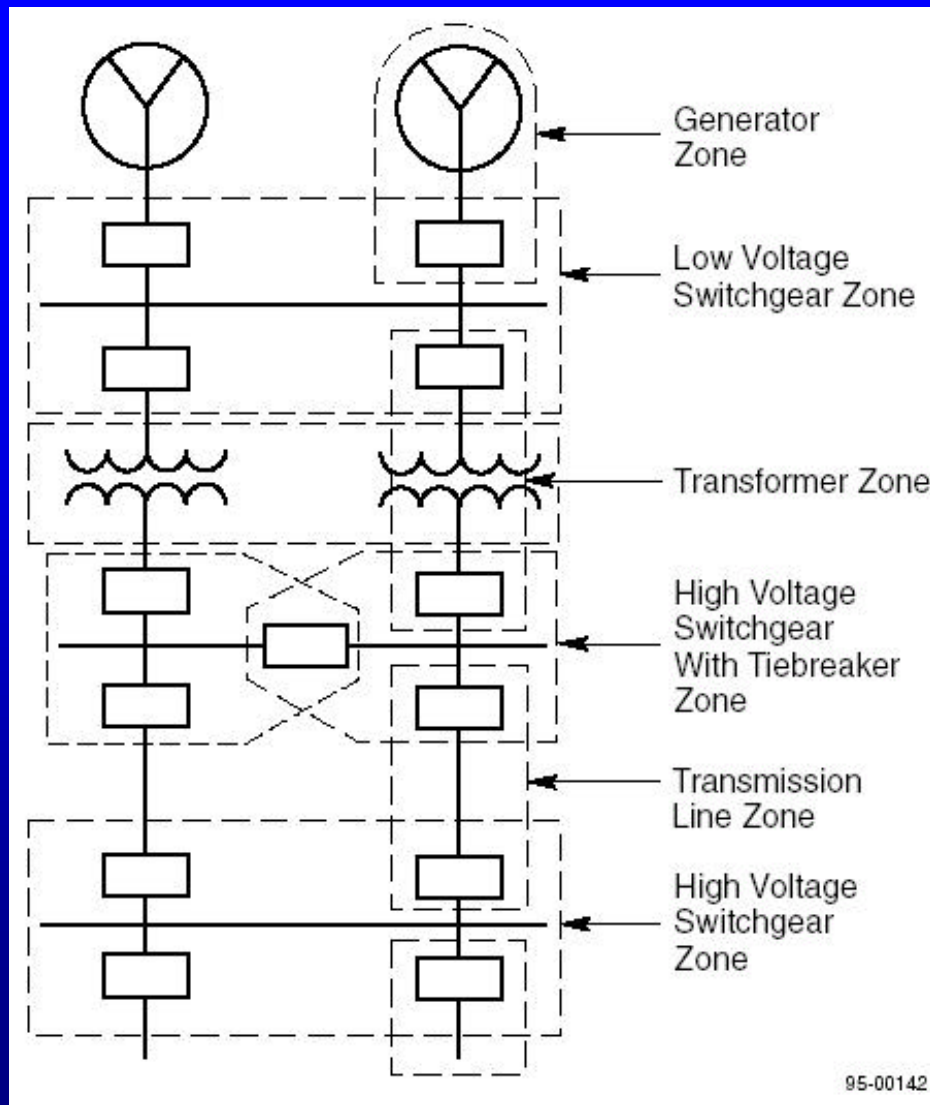

Protective Relays

- **Voltage and current transformers play a vital role in the power protection scheme.**
 - Used to isolate and protect both people and devices from high voltage and current.
- **The performance of a relay is only as good as the voltage and current transformers connected to it.**

Protective Relays

- ☞ **Some overcurrent relays are equipped with an instantaneous overcurrent unit:**
 - **Operates when the current reaches its minimum pickup point.**
 - **An instantaneous unit is a relay having no intentional time delay.**

Protective Relays

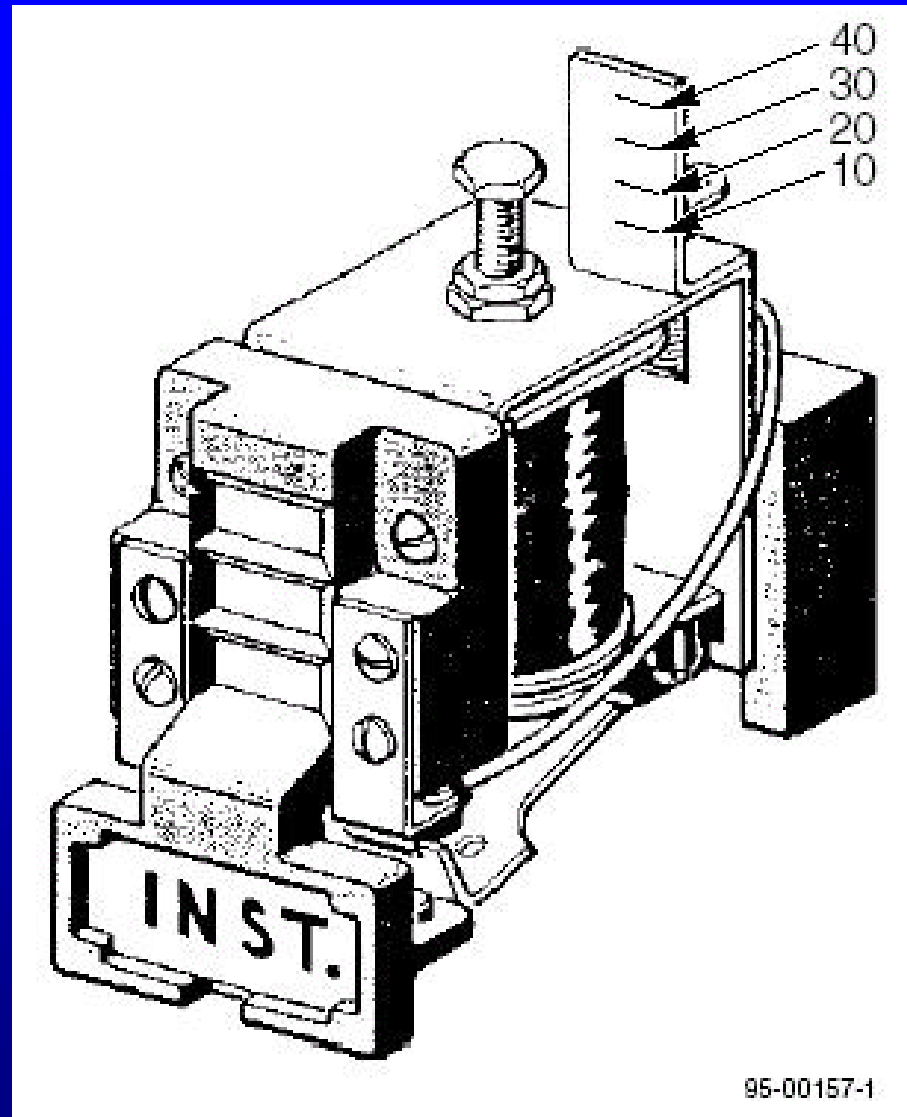

Protective Relays

- ☞ **Things that can go wrong:**
 - An open or shunted current transformer
 - Open coil
 - Dirty contacts
- ☞ **Protective relays, like circuit breakers, require periodic inspection, maintenance, and testing to function properly.**

Protective Relays

- **Most manufacturers recommend that periodic inspections and maintenance be performed at intervals of one to two years.**
- **The intervals between periodic inspection and maintenance will vary:**
 - **Environment**
 - **Type of relay**

Protective Relays

- ☞ **The periodic inspections, maintenance, and testing are intended to ensure that:**
 - **Protective relays are functioning properly**
 - **Have not deviated from the design settings**
 - ◆ **If deviations are found, the relay must be retested and serviced as described in the manufacturer's instructions.**

Flash Hazard Analysis

- ☞ **All calculations require the arc clearing time.**
 - Determine incident energy
 - Establish the flash protection boundary
- ☞ **Clearing time is derived from the engineering coordination study**
 - Based on what the protective devices are supposed to do.

Flash Hazard Analysis

- **Maintenance is a very critical part of the flash hazard issue.**
- **A preventive maintenance program on these circuit protective devices is needed.**
- **Inadequate maintenance can cause unintentional time delays.**

Flash Hazard Analysis

☞ Example:

- A low-voltage power circuit breaker had not been operated or maintained for several years
- The lubrication had become sticky or hardened
- Circuit breaker could take several additional cycles, seconds, minutes, or longer to clear a fault condition.

Flash Hazard Analysis

- ☞ **Flash Hazard Analysis is performed:**
 - Based on what the system is suppose to do - 5 cycles
 - Unintentional time delay, due to a sticky mechanism
 - Breaker clears in 30 cycles
 - The worker could be seriously injured or killed because he/she was under protected.
- ☞ **Arc/Flash situation: 20,000-amp short-circuit, 480 volts, 3-inch arc gap, the worker is 18 inches from the arc, with a 5 cycle clearing time for a 3-phase arc in a box (enclosure).**

Next slide illustrates this:

Calculation for 5 cycles

C:\Flux\FLUX.EXE

responsibility any damage that may arise from its use.

XX

Enter the arc current(amps) ? 20000
Enter the arc gap(inches) ? 3
Enter the supply voltage(volts) ? 480
Arc column area 43.03264 sq. inches
Arc column cir. 14.34421 inches
Arc diameter 4.565908 inches
Arc power in watts - 1781250
Arc power in calories/sec - 425540.6
Heat flux on surface of arc 1533.146 cal/cm²-sec
Enter the distance from the arc to the receiving surface ? 18
Transfer Shape Factor 1.482744E-02
Heat Flux at Receiving Surface 22.73263 cal/cm²-sec
Enter the number of cycles for the arc duration ? 5
Arc Duration 8.333001E-02 seconds
Total Calories per Sq. Cm. at Receiving Surface 1.89431

Do You Wish To Run Another Case? (Y or N) ? _

Calculation with a 5 Cycle Clearing Time

This value of 1.89431 cal/cm² is based on a single-phase arc in open-air. As a general rule of thumb, the value of 1.89431 would be multiplied by a factor of 2 for a single-phase arc in a box ($2 \times 1.89431 = 3.78862$ cal/cm² – Category 1) and by a factor of 3.4 for a multi-phase arc in a box ($3.4 \times 1.89431 = 6.440654$ cal/cm² – Category 2). (The protection category is based on NFPA 70E-2000, Part II, Table 3-3.9.3.)

Due to a sticky mechanism the clearing time increases to 30 cycles.

Next slide illustrates this:

Calculation with a 30 Cycle Clearing Time

The value of 11.36586 cal/cm² is based on a single-phase arc in open-air. Again, as a general rule of thumb, the value of 11.36586 would be multiplied by a factor of 2 for a single-phase arc in a box ($2 \times 11.36586 = 22.73172$ cal/cm² – Category 3) and by a factor of 3.4 for a multi-phase arc in a box ($3.4 \times 11.36586 = 38.643924$ cal/cm² – Category 4). **(The protection category is based on NFPA 70E-2000, Part II, Table 3-3.9.3.)**

As can be seen, maintenance is extremely important to an electrical safety program. Maintenance must be performed according to the manufacturer's instructions in order to minimize the risk of having an unintentional time delay in the operation of the circuit protective devices.

Summary

- ☞ **Proper maintenance can be performed and power systems kept in a safe, reliable condition with the proper mixture of:**
 - **Common sense**
 - **Training**
 - **Manufacturers' literature and spare parts**

Summary

- **Circuit breakers, if installed within their ratings and properly maintained, should operate trouble-free for many years.**
- **If operated outside of their ratings or without proper maintenance:**
 - **Catastrophic failure of the power system, circuit breaker, or switchgear can occur**
 - **May cause serious injury or even death of employees working in the area.**