

Fast Reactor Spent Fuel Processing: Experience and Criticality Safety

**Chad Pope
Idaho National Laboratory
P.O. Box 1625
Idaho Falls, ID 83415-6108
208-533-7745 office
208-533-7239 fax
chad.pope@inl.gov**

INTRODUCTION

This paper discusses operational and criticality safety experience associated at the Idaho National Laboratory Fuel Conditioning Facility. The facility uses an engineering scale pyrometallurgical process to treat fast reactor spent fuel from the Experimental Breeder Reactor II. Operations in the facility began June 7, 1996, and continue today. The process is necessary because the Experimental Breeder Reactor II fuel design uses sodium metal bonding between the fuel pin and stainless steel cladding. The use of sodium prevents the spent fuel from being suitable for direct geologic disposal. Since the Experimental Breeder Reactor II fuel is metallic rather than oxide, a pyrometallurgical process can be used for treatment rather than the traditional solvent extraction method.

PROCESS DESCRIPTION

The Fuel Conditioning Facility is shown in Figure 1. The Fuel Conditioning Facility is in the foreground with the Experimental Breeder Reactor II, the domed building, in the background. The two facilities are connected, allowing direct spent fuel transfers from the reactor to the processing facility.



Figure 1 Fuel Conditioning Facility.

The entire pyrometallurgical process is conducted remotely in a hot cell environment. Figure 2 shows the general process flow and Figure 3 shows the Fuel Conditioning Facility hot cell layout. The rectangular portion of the hot cell contains an air atmosphere and is used for spent fuel and product storage. The annular portion of the hot cell contains an inert argon atmosphere and is used for all processing steps.

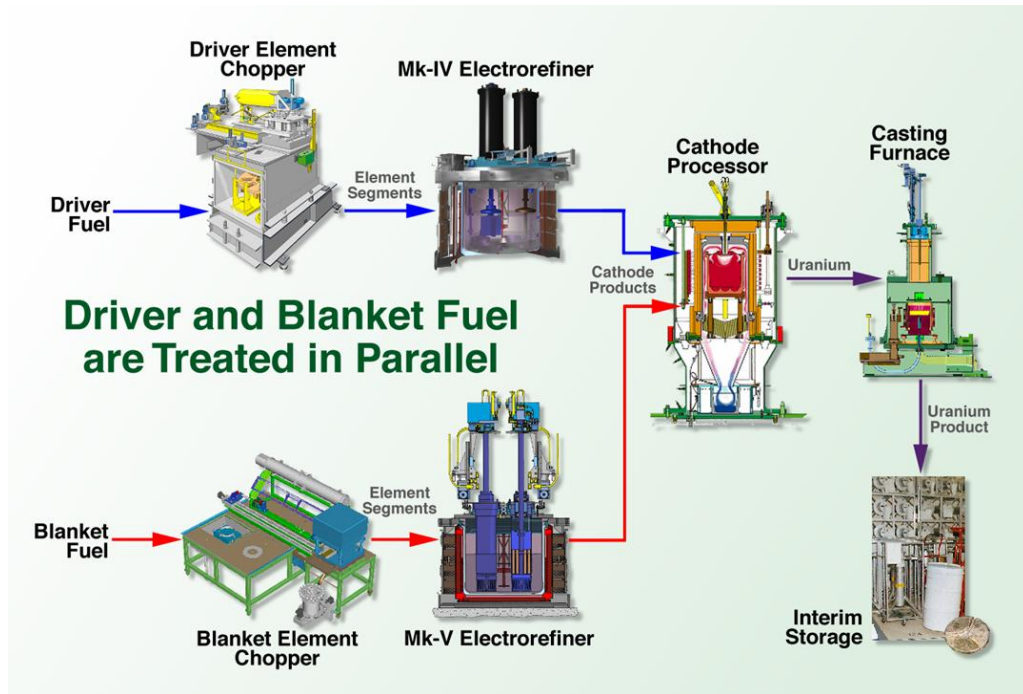

Figure 2 Process Flow.

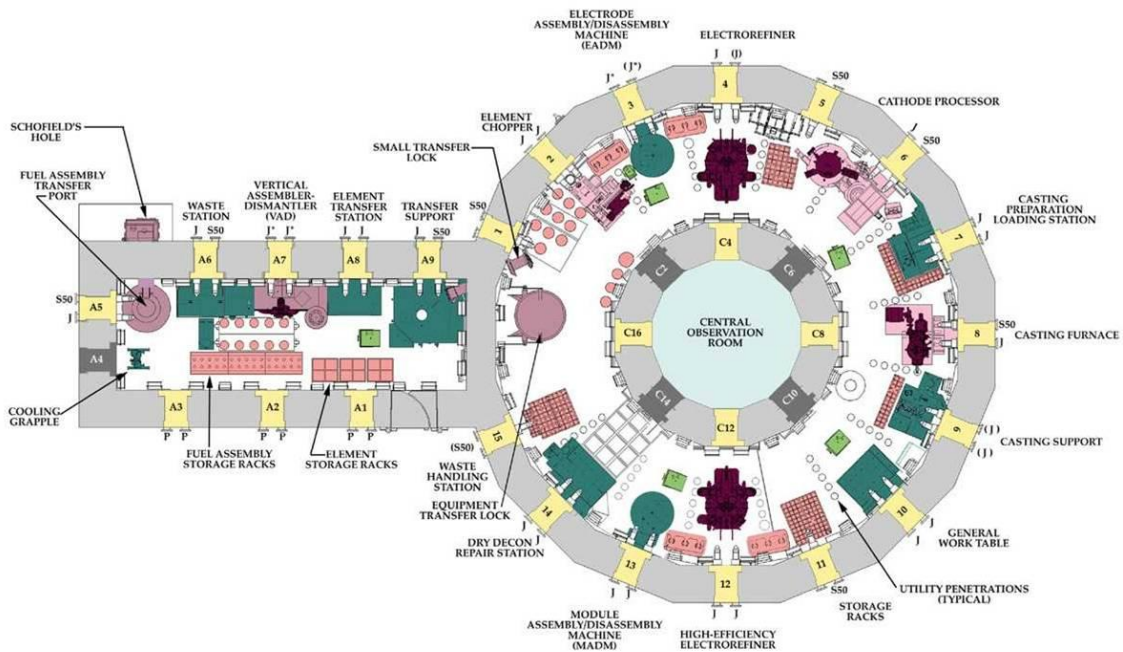

Figure 3 Facility Layout.

The spent fuel is divided into two basic categories: driver and blanket. Driver spent fuel consists of a uranium-zirconium alloy fuel pin, sodium bonding, and stainless steel cladding. Sodium metal bonding is added between the fuel pin and cladding to enhance heat transfer in the reactor. A wire wrap around the cladding is used to provide separation between adjacent elements. The fuel pin alloy is typically 90 wt.% uranium and 10 wt.% zirconium. The uranium enrichment is typically 67%. Blanket elements consist of a depleted uranium metal pin, sodium bonding, and stainless steel cladding. The process starts with chopping spent fuel elements into element segments.

Figure 4 shows the basket that holds the chopped elements segments and a basket containing mock element segments. The driver element segments are approximately 6 mm long and 6 mm in diameter. The blanket element segments are approximately 12 mm long and 12 mm in diameter. The basket consists of four compartments in a cruciform arrangement and can hold approximately 20 kg of element segments. Typical batches consist of approximately 12 kg.

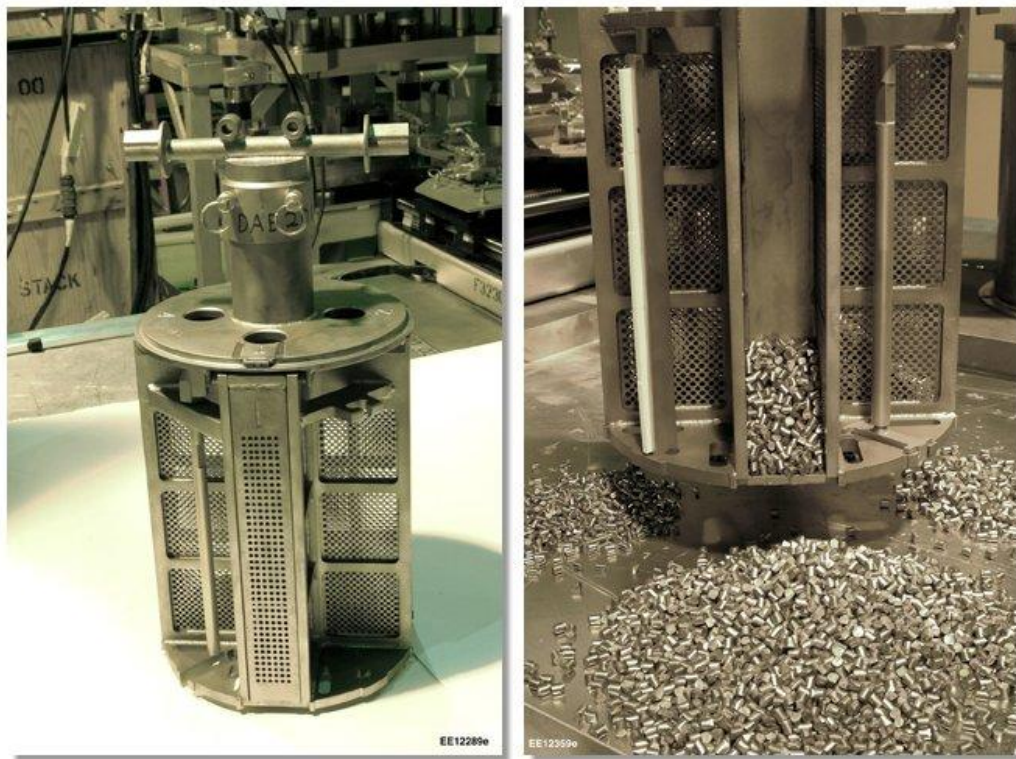

Figure 4 Element Segment Basket.

Once filled, the basket is lowered into the electrorefiner which contains molten salt (LiCl-KCl). A stainless steel mandrel is also lowered into the salt. The basket compartment walls are perforated which allows molten salt to come into contact with the element segments when the basket is submerged in the electrorefiner. The electrorefiner is shown in Figure 5. The electrorefiner vessel is maintained at $500\text{ }^{\circ}\text{C}$ and contains $\sim 300\text{ kg}$ of molten salt and $\sim 100\text{ kg}$ of molten cadmium metal. The salt serves as electrolyte and the cadmium metal serves as an anode or cathode depending on the desired vessel configuration.

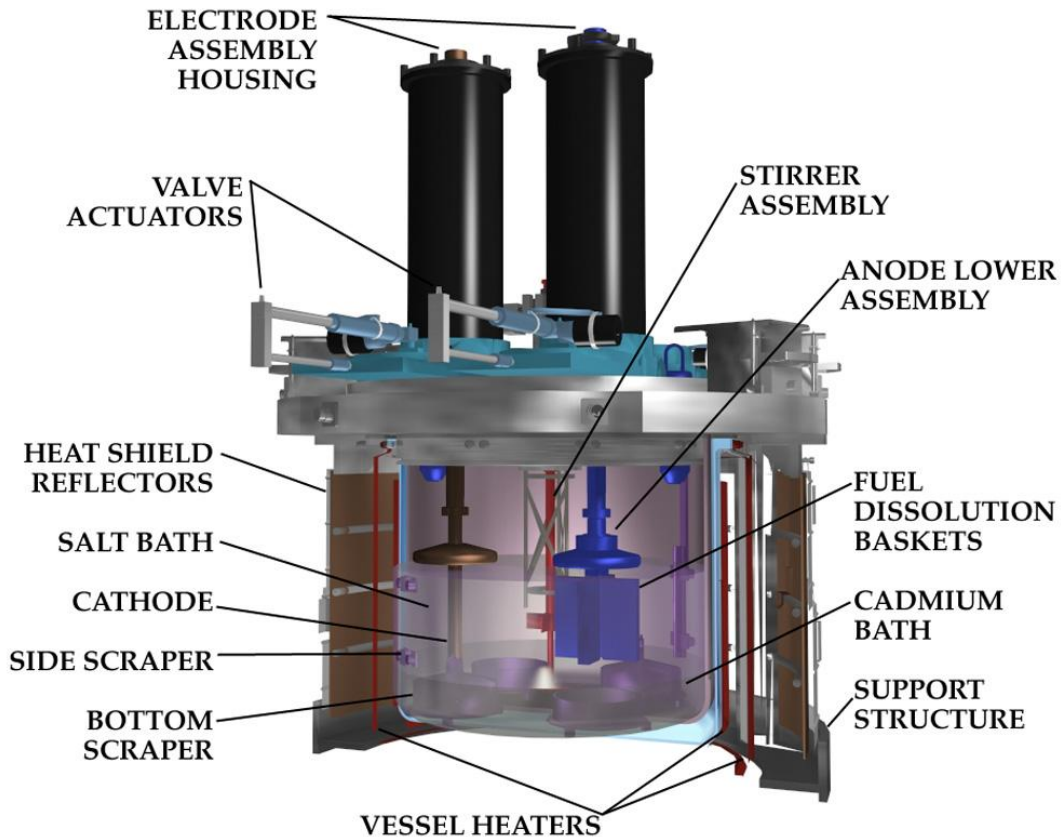

Figure 5 Electrorefiner.

In the electrorefiner, active metal fission products, transuranic metals, and sodium metal in the spent fuel undergo chemical oxidation and form chlorides. Voltage is applied between the basket, which serves as an anode, and the mandrel, which serves as a cathode, causing metallic uranium in the spent fuel to undergo electro-chemical oxidation thereby forming uranium chloride. Simultaneously at the cathode, uranium chloride undergoes electro-chemical reduction and deposits uranium metal onto the mandrel. Typical applied voltage is ~ 0.35 V and typical current is ~ 50 - 100 A. The applied voltage is kept below one volt to prevent oxidation of iron in the basket. The amount of uranium deposited on the cathode is directly proportional to the integrated current. Fission products, plutonium, and other transuranic metals remain as chlorides in the salt and are eventually disposed of as waste.

Upon removal from the electrorefiner, the uranium metal adhering to the mandrel and accompanying entrained salt are placed in a graphite crucible. The deposit is typically 80 wt.% uranium and 20 wt.% salt. The graphite crucible typically holds ~ 19 kg of the dendritic cathode deposit. If the deposit originated from driver material, depleted uranium is added to the crucible to reduce the uranium enrichment below 50%. The crucible is transferred to a distillation furnace, which is operated at a temperature of 1200 °C and a pressure of 150 miliTorr. While in the furnace, the uranium metal melts and forms an ingot, and the entrained salt boils and subsequently condenses in a separate crucible. Figure 6 shows a cathode deposit. Figure 7 shows the cathode processor distillation furnace and the uranium (upper right) and salt (lower right) ingots produced by the furnace.



Figure 6 Cathode Deposit.

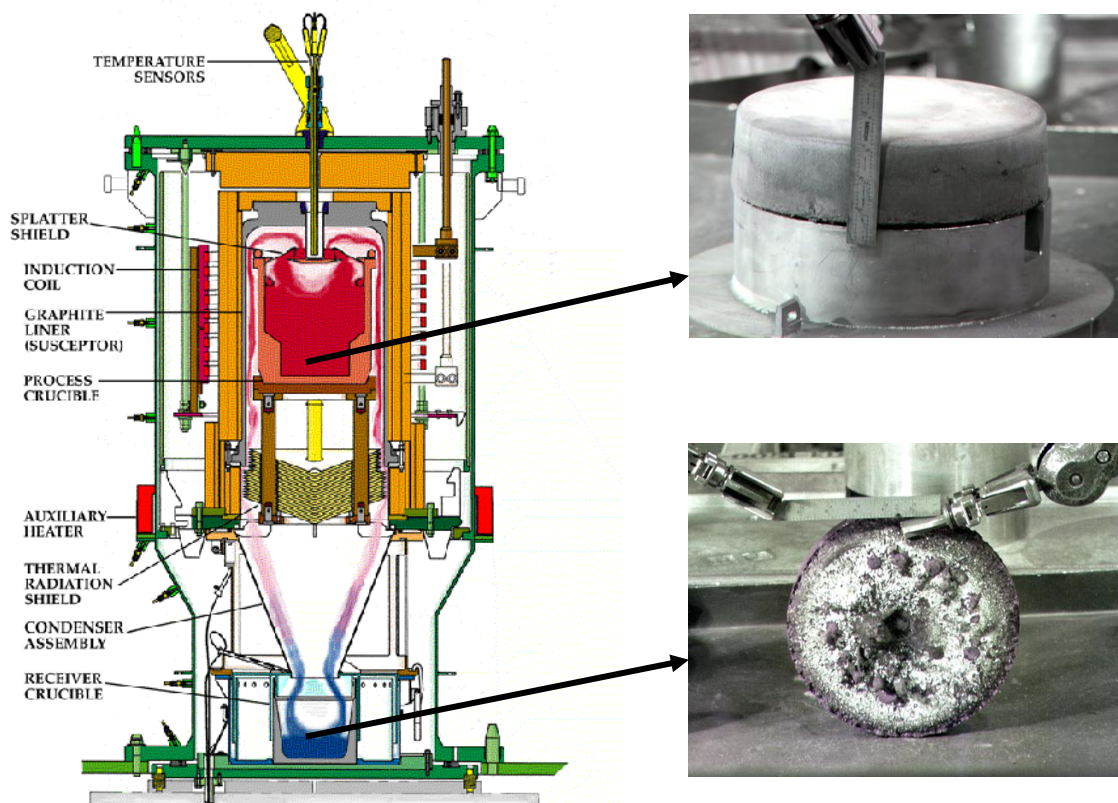

Figure 7 Cathode Processor and Ingots.

The final step in the process applies only to uranium derived from driver fuel. The ingot from the cathode processor is placed in a graphite crucible and more depleted uranium is added. The crucible is placed in a casting furnace. The casting furnace is used to melt the uranium ingot and depleted uranium into a homogeneous ingot with uranium enrichment below 20%. Following processing, all ingots are transferred to a long term storage facility.

RESULTS

During the 10 year operating history, over 12,000 driver fuel elements have been processed resulting in the production of 2,500 kg of 20% enriched uranium. Also, over one thousand blanket fuel elements have been processed resulting in the production of 2,400 kg of depleted uranium. These operations required over 35,000 fissile material transfers between zones and over 6,000 transfers between containers.

Numerous lessons were learned over the 10 year operating history. One fundamental lesson learned is that engineering scale demonstration is essential. Operational improvements related to electrorefining came as a direct result of engineering scale demonstration. Initial operations in the electrorefiner were hampered by the buildup of cadmium. Cadmium buildup was the result of cadmium vaporization and subsequent condensation. Figure 8 shows the buildup of cadmium on the portion of the electrorefiner where the anode or cathode is connected. The cadmium buildup hampered use of the clamping device. Subsequent installation of a cold-trap in the electrorefiner allowed preferential capture of cadmium. Many similar process improvements occurred as a result of engineering scale demonstration.



Figure 8 Cadmium Buildup.

An important lesson learned in the area of criticality safety involved preparing for equipment failure. Use of graphite crucibles presents the possibility of a crucible failure. Ensuring that failure of a crucible during furnace operation can be accommodated from a criticality safety perspective was an important part of the equipment design process. Figure 9 shows the results of an actual crucible failure during operation of the cathode processor furnace. The figure shows the crucible sitting on a pedestal with solidified uranium adhering to the heat shields. The right side of the figure shows a mirror which reveals the hole that developed in the crucible during furnace operation. Establishing mass limits that accommodate this situation simplified recovery efforts.

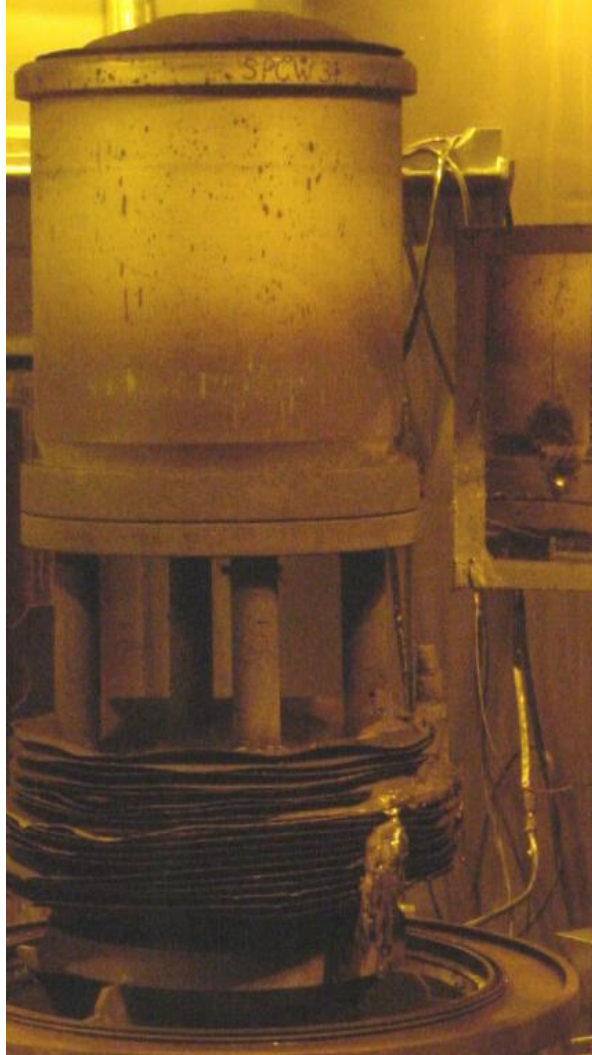

Figure 9 Failed Crucible.

Another important criticality safety related lesson learned has been in the area of comprehensive near real-time computerized material tracking. Over one hundred criticality safety evaluations were required to support both initial and revised operating approaches. All criticality safety-related limits and controls for the entire process are contained in a single document, which required over 30 revisions to accommodate process changes. Operational implementation of the limits and controls includes use of a near real-time computerized tracking system. The tracking system uses an Oracle database coupled with numerous software applications. The computerized tracking system uses direct fuel handler interaction with every movement of material. Improvements to this system during the 10 year history include introduction of web based operator interaction, tracking of moderator materials, and the development of a plethora database queries to assist in day to day operations as well as obtaining historical information.

Use of the tracking software during material movement activities involves a specific sequence of operator and computerized checks to ensure the proposed movement is within the established limits and controls. Figure 10 shows typical web pages related to the movement of a container from one controlled location to another. The process involves four distinct phases with operator

