

Advanced Test Reactor Design Basis Reconstitution Project Issue Resolution Process

**Steven D. Winter
Gregg L. Sharp
William E. Kohn
Richard T. McCracken**

**Energy Facility Contractors Group
Safety Analysis Workshop
May 19-24, 2007**

Overview

- **Design Basis Reconstitution Project at the ATR**
- **Issue Resolution Process**
- **Lessons Learned to Date**

Advanced Test Reactor (ATR)

- Located at Reactor Technology Complex at INL
- 250 MW Maximum Thermal Power
- Core inlet conditions - 360 psig @ 125 °F
- Provides high neutron flux for reactor fuels and materials experiments
- Provides other irradiation services

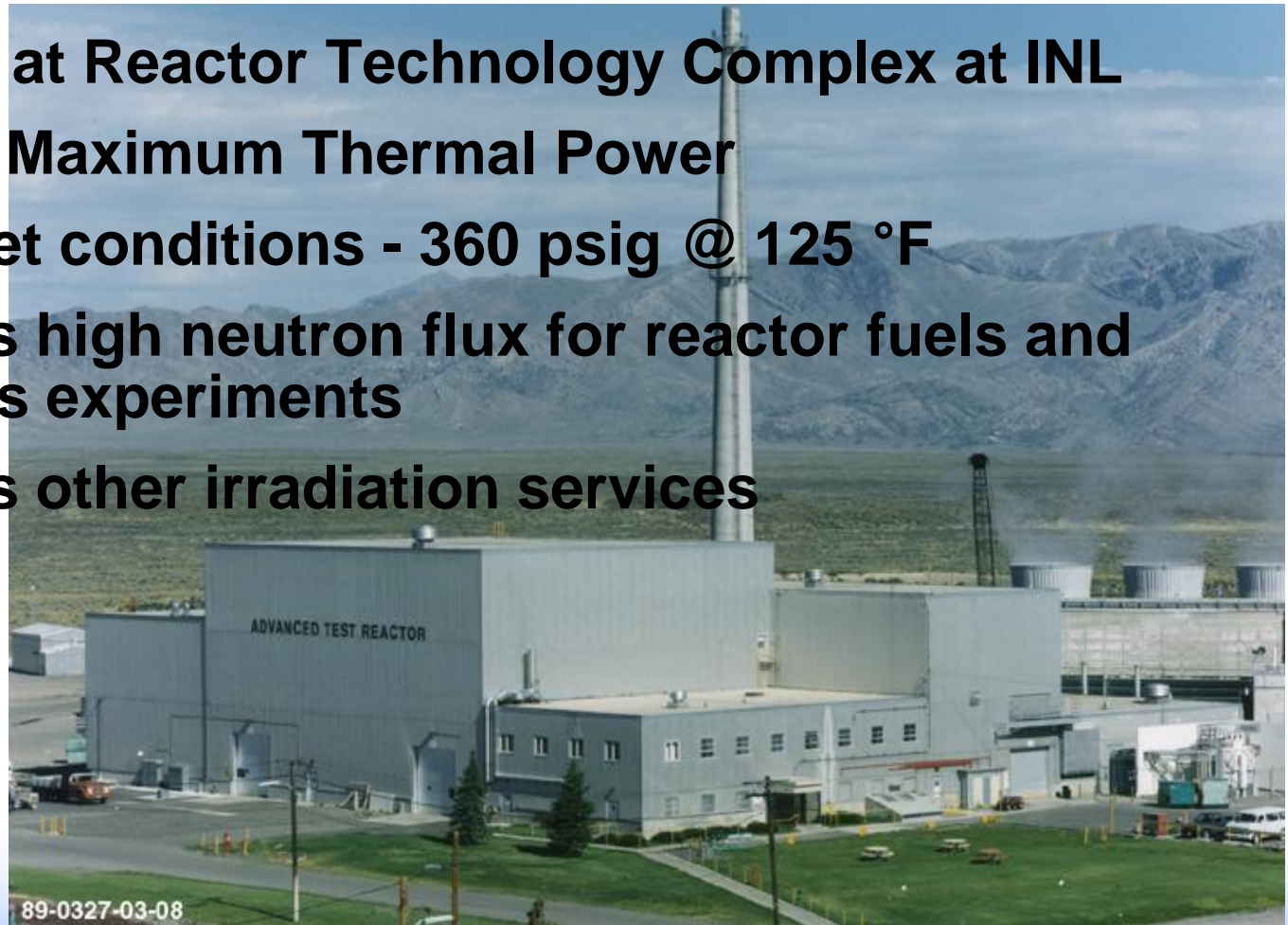

ATR Safety Basis History

- 1965 Original Safety Analysis Report
- 1976 Design Basis Report
- 1998 Upgraded Final Safety Analysis Report

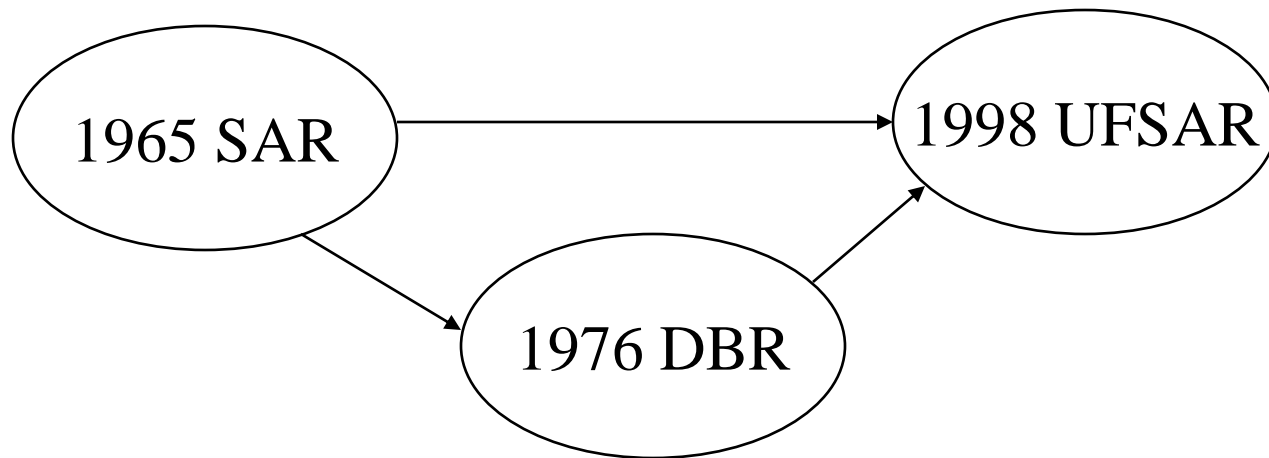

Design Basis Reconstitution Program (DBRP)

- **Update design basis to commercial plant levels**
- **Identify system-level requirements and performance criteria for safety systems**
- **Validate functionality of safety systems and structures**
- **Includes INL staff,
contracted industry expertise,
and knowledgeable former employees.**

Three Major Elements of a DBRP

```
graph TD; A([Design Basis Documents]); B([Physical Configuration]); C([SAR Configuration]);
```

Design Basis Documents

Physical Configuration

SAR Configuration

Three Major Elements of a DBRP

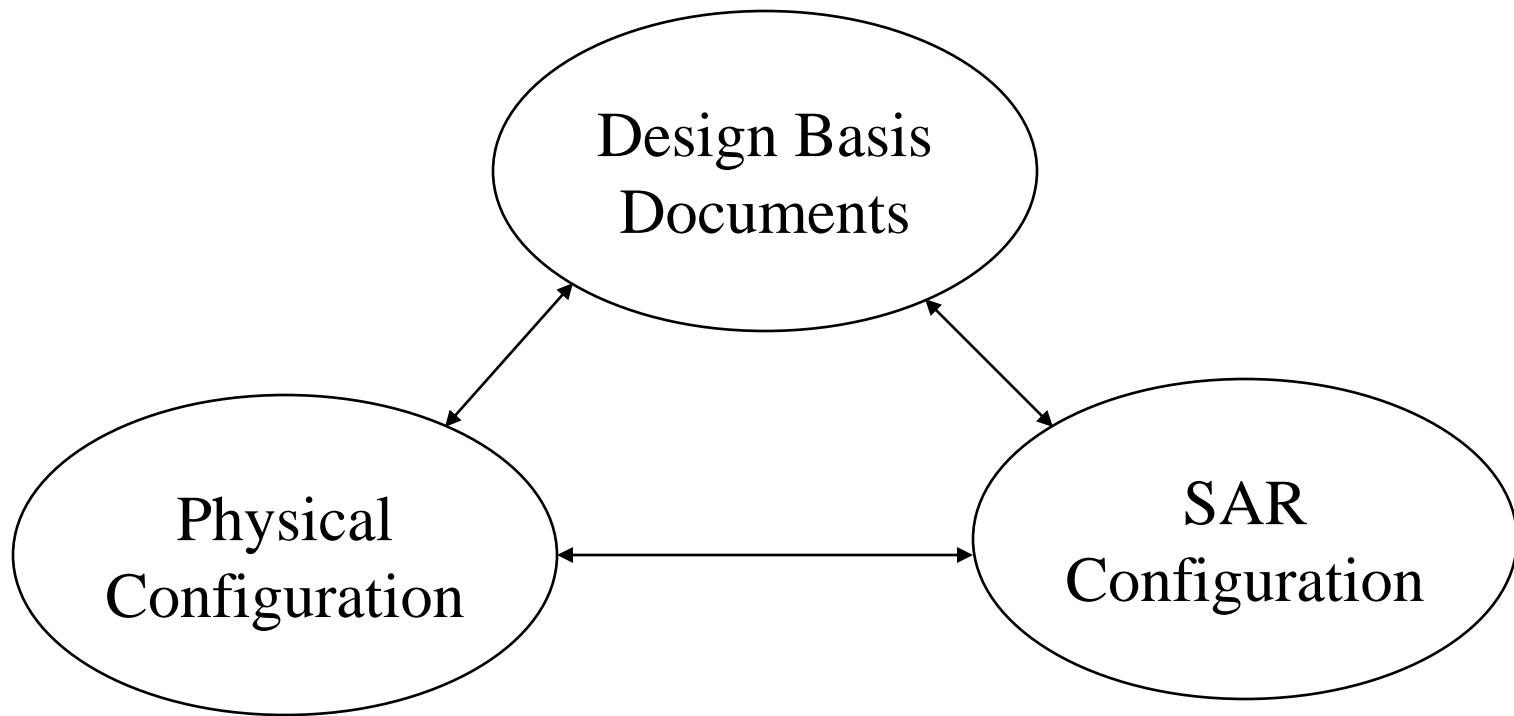

Three Major Elements of a DBRP

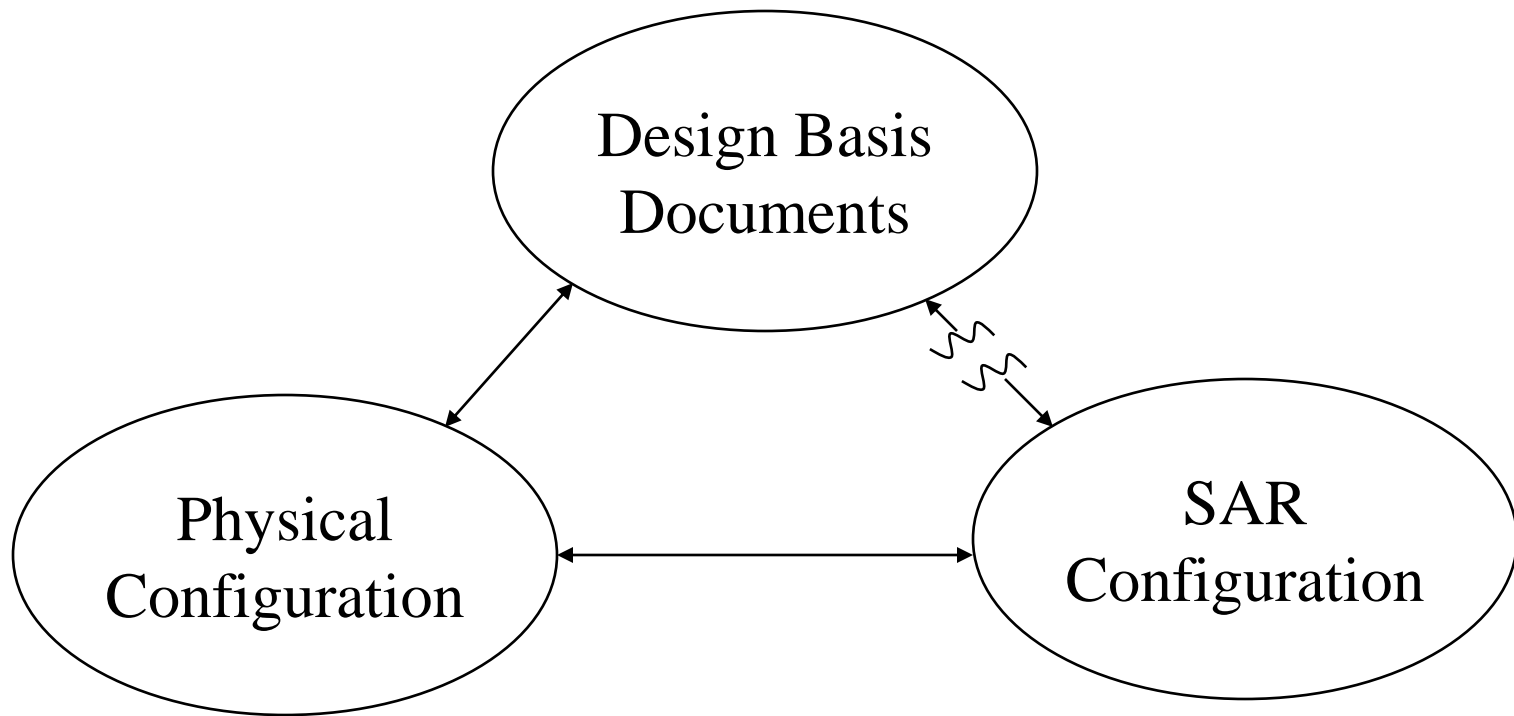

Issue Resolution Process

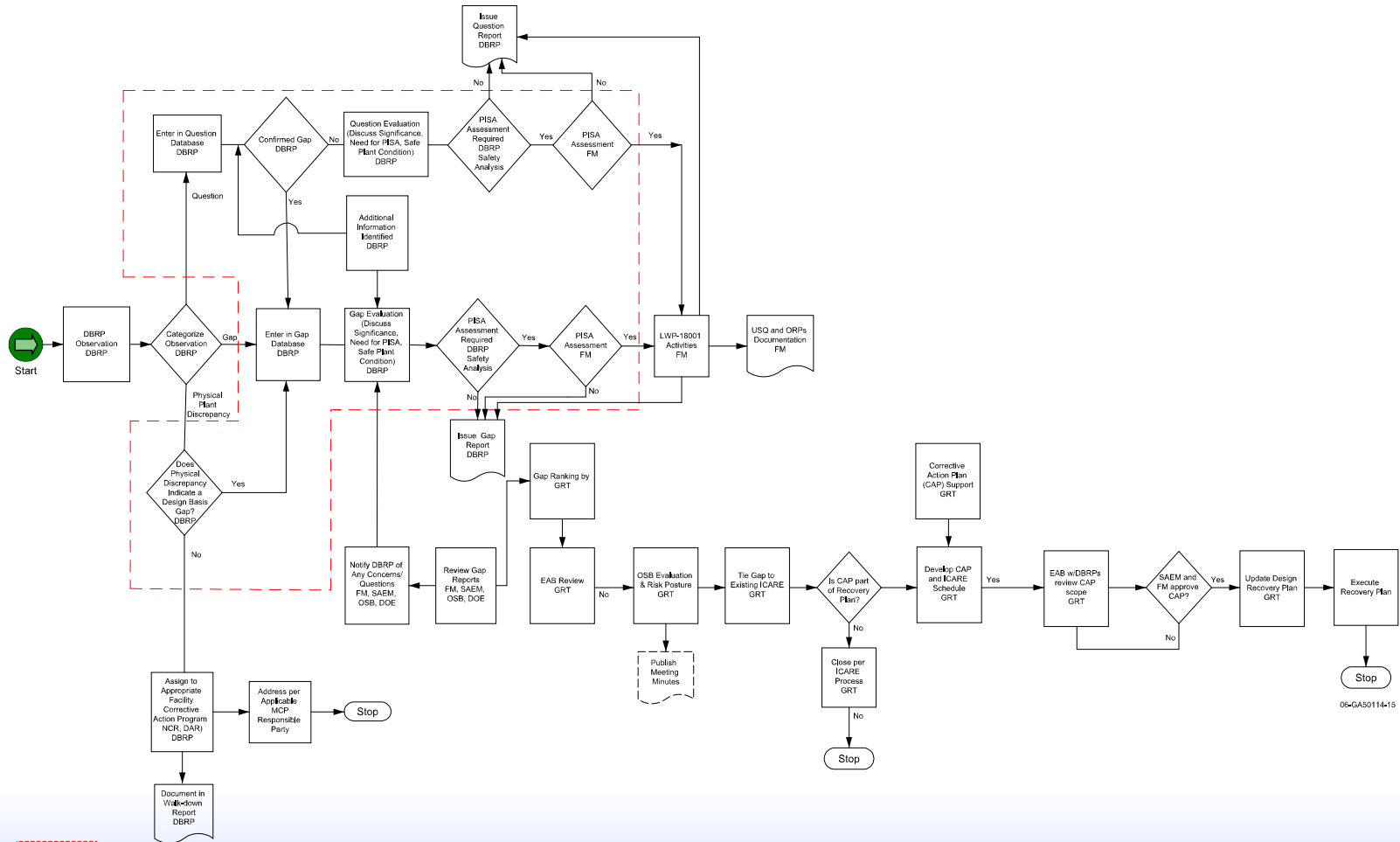

06-GAS0114-15

PISA Process

Entry into the Process

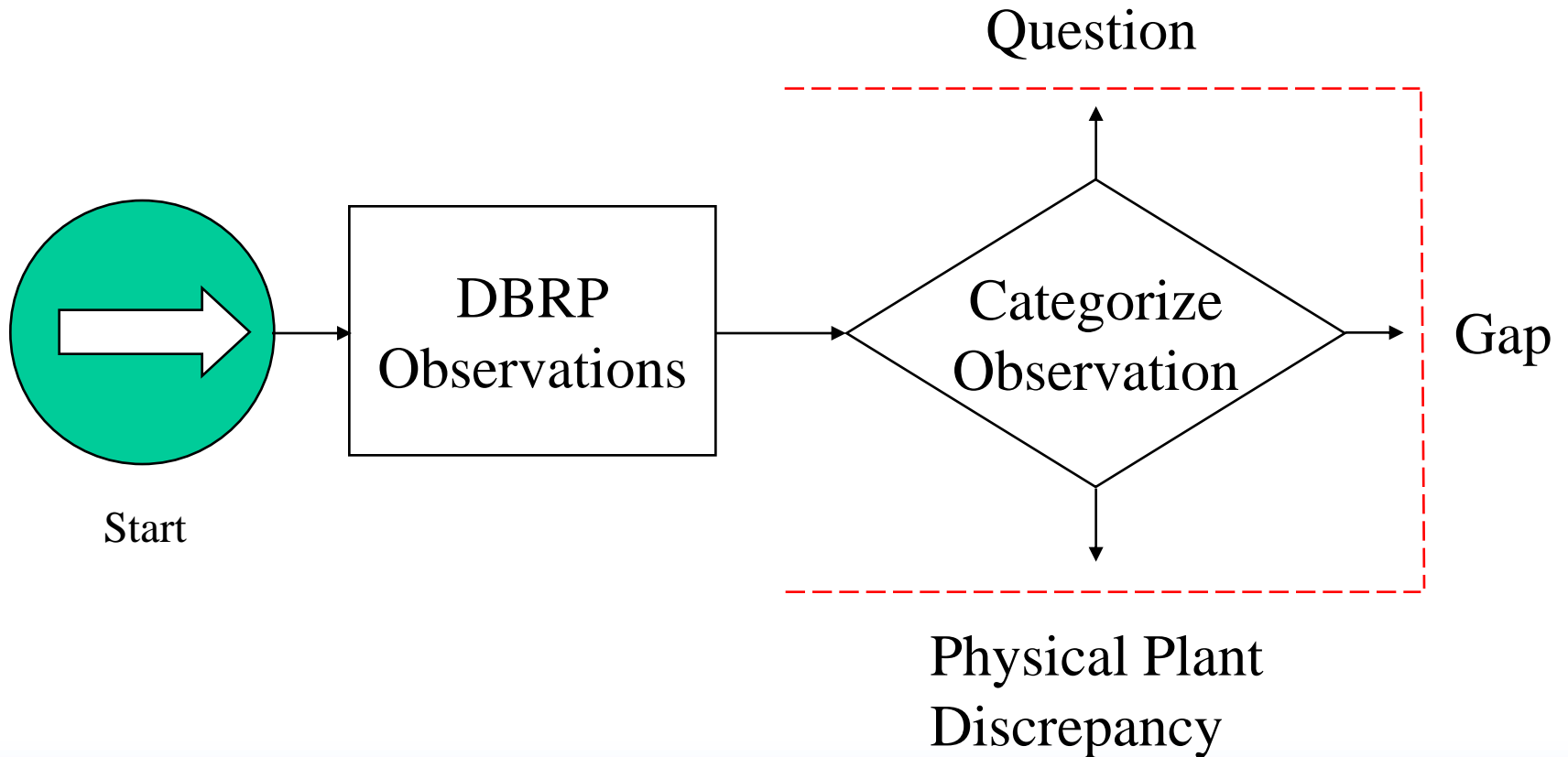

Physical Plant Discrepancy (PPD)

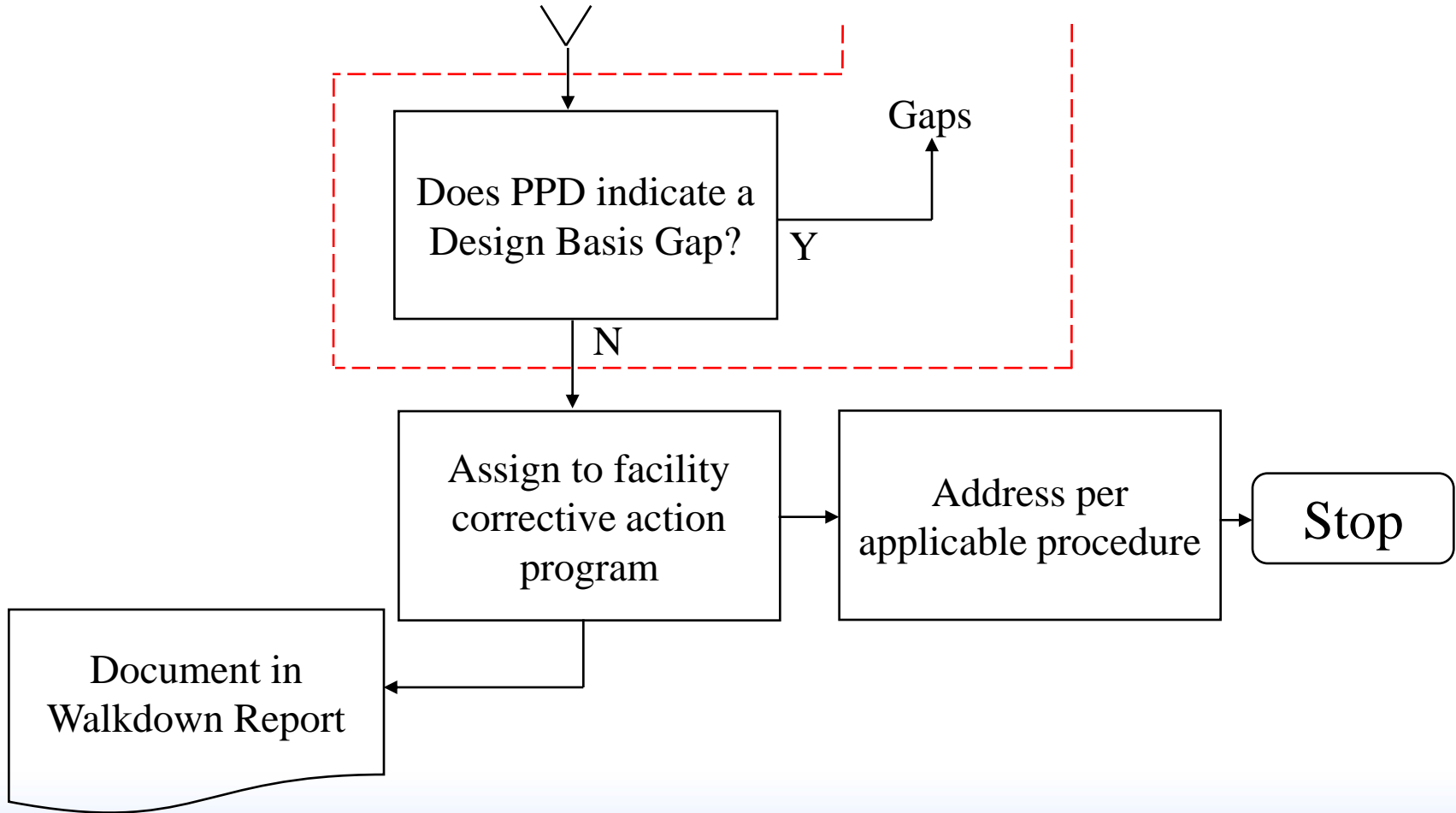

Questions

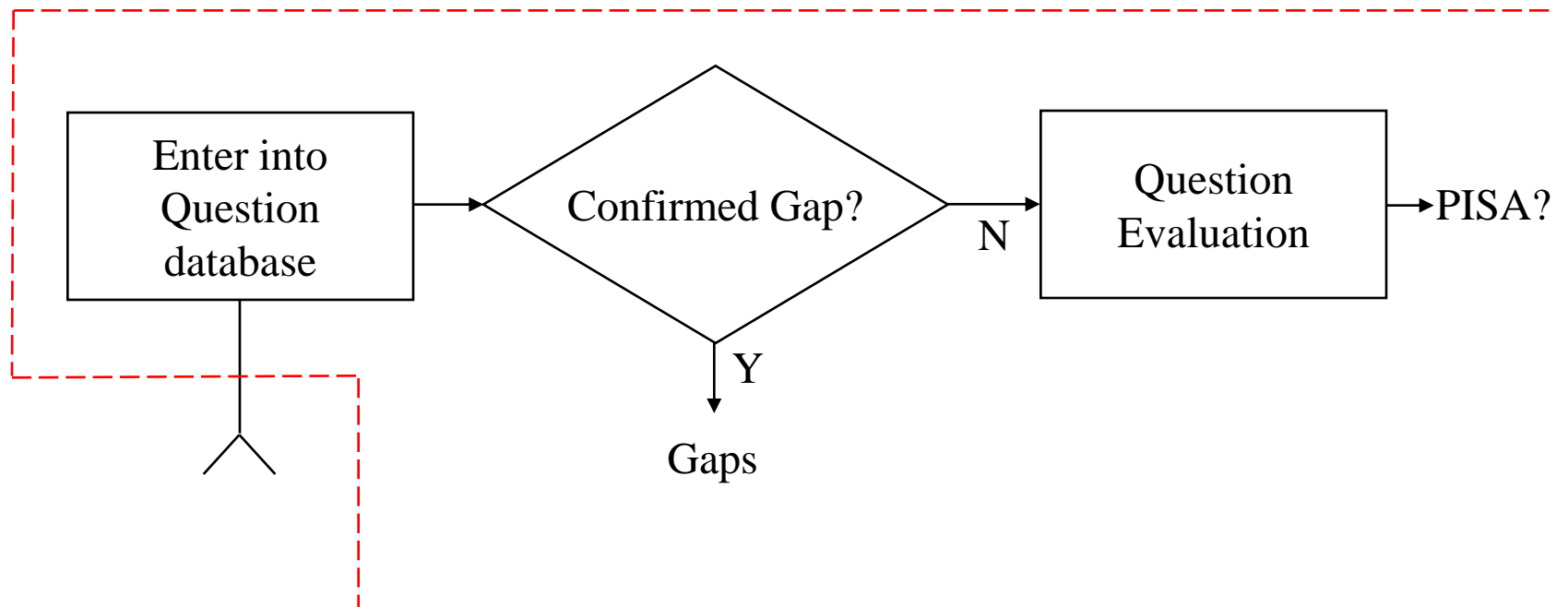

Questions – PISA Assessment

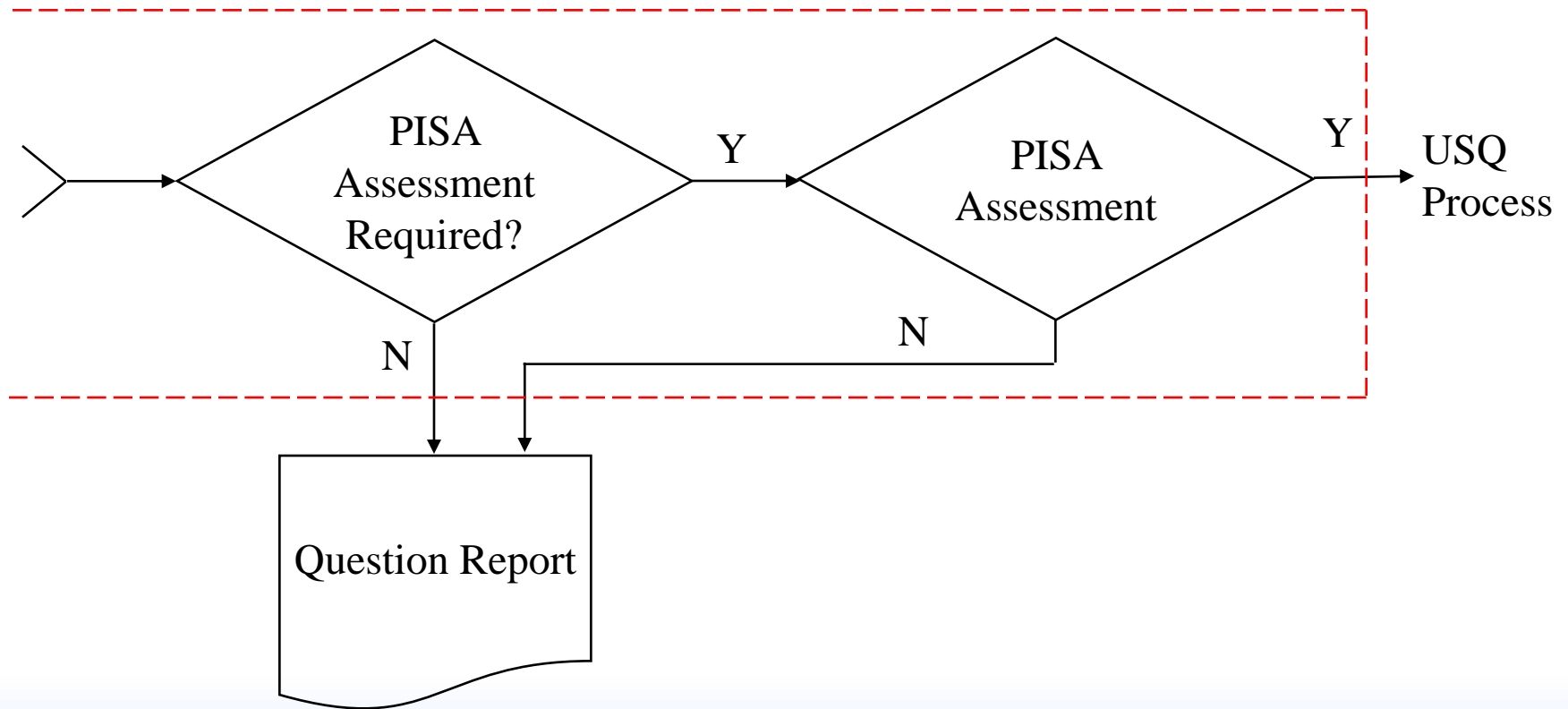

Gaps

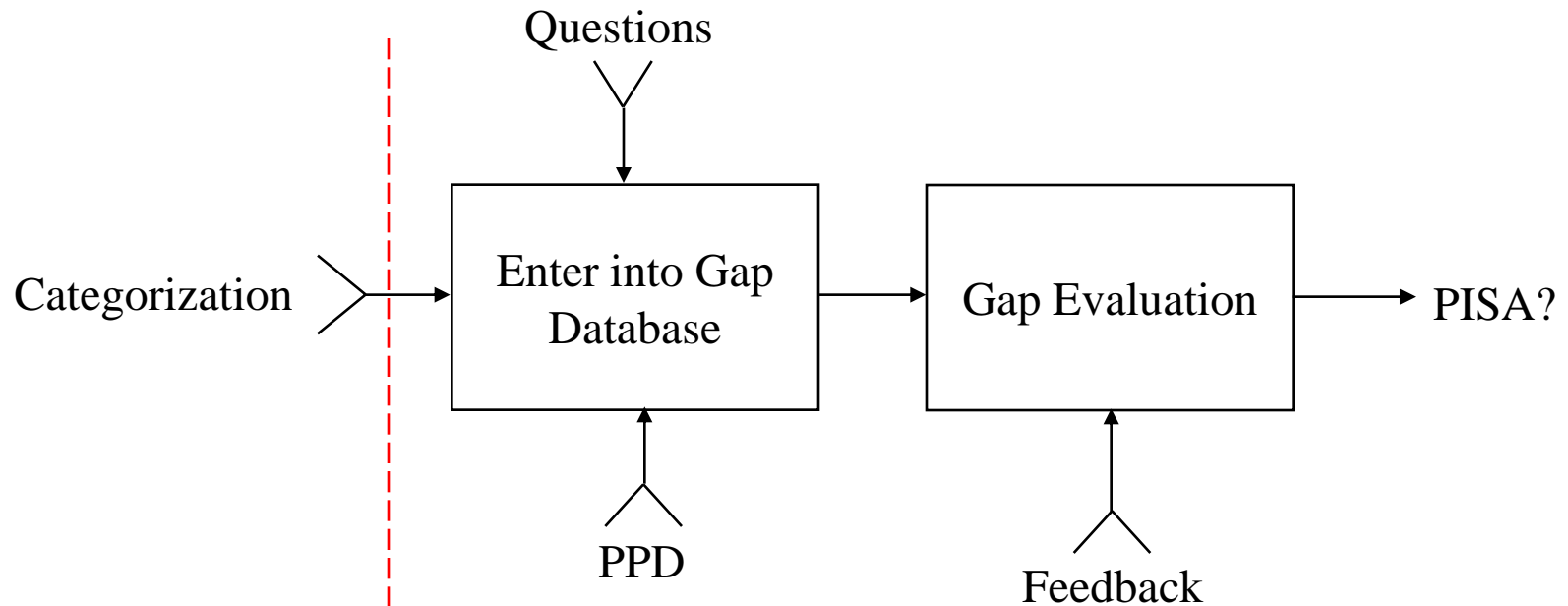

Gaps – PISA Assessment

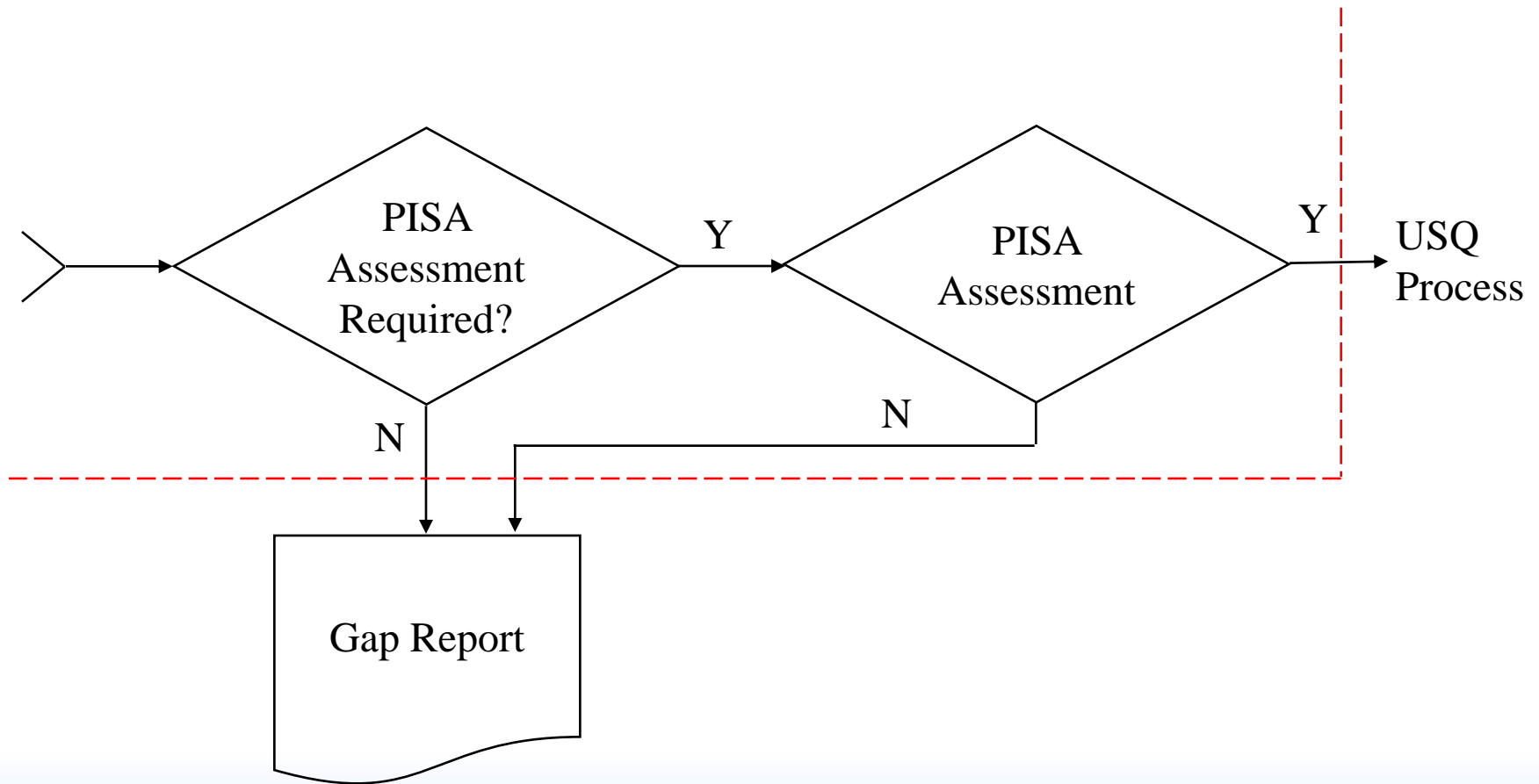

USQ Process

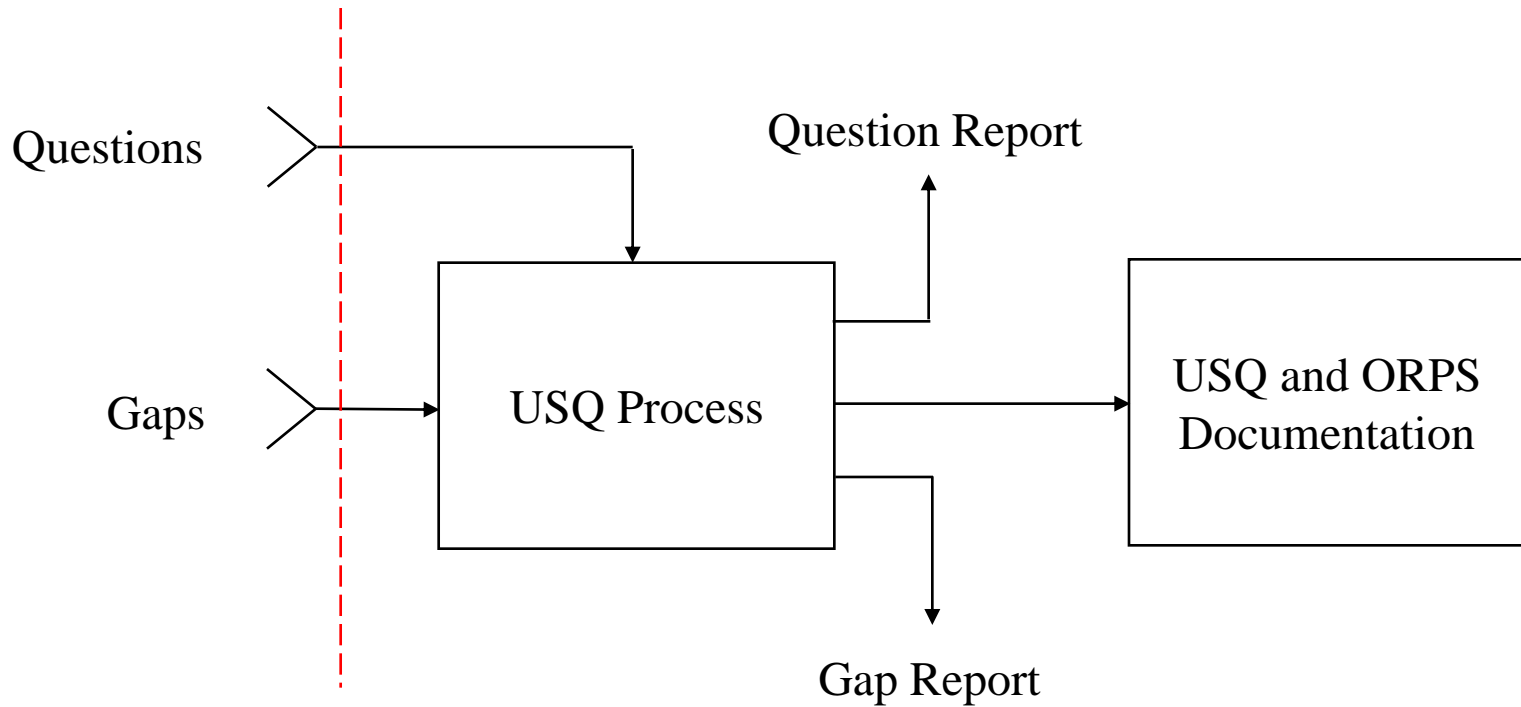

Review

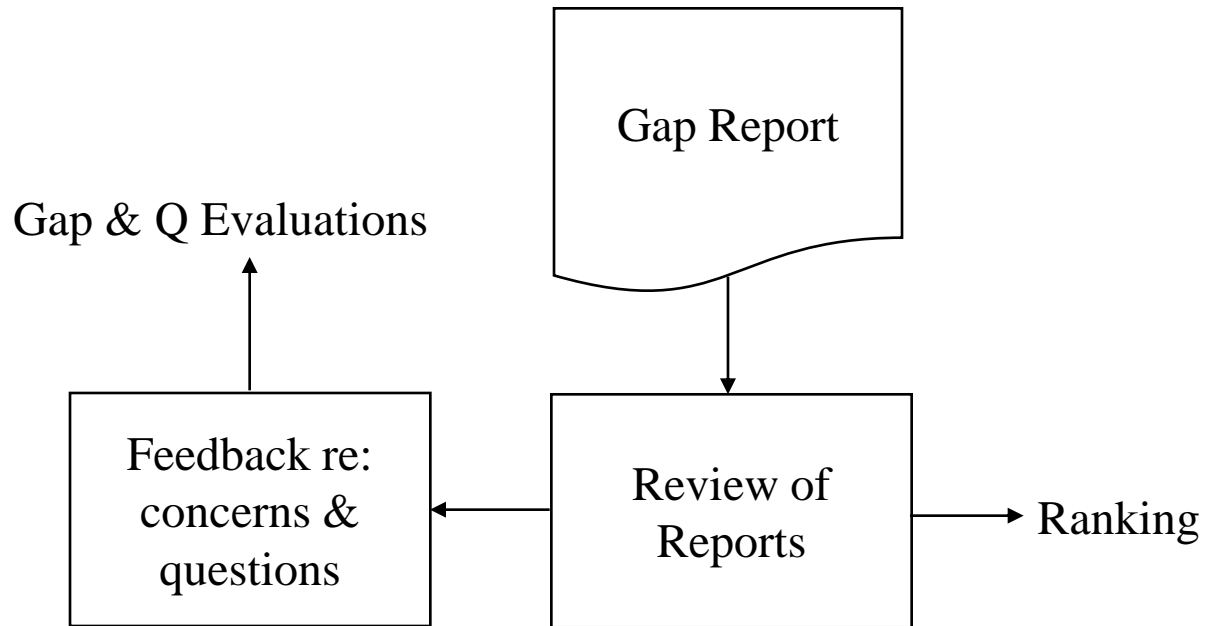

Gap Ranking

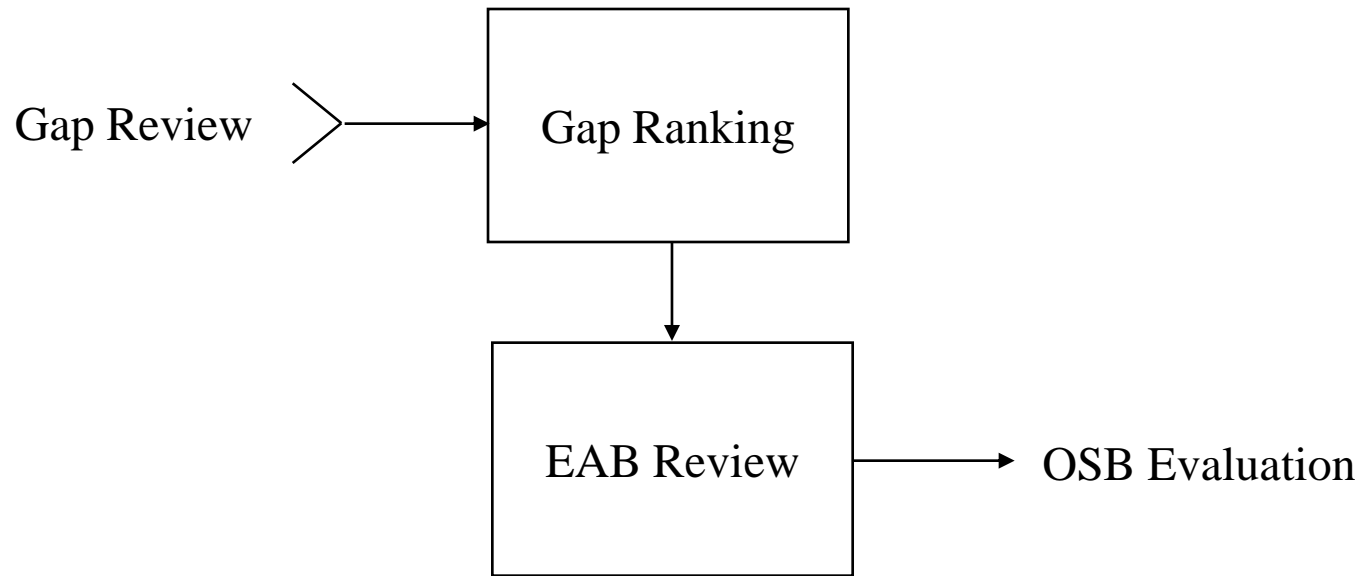

Gap Ranking Table

Impact	Points
PISA – Reactor Shutdown	100
PISA – Limitations on Rx Operations	75
PISA – Other Controls Than Above	50
Positive USQ	20
SAR / TSR revision(s)	15
None of the Above	0
Subjective Score (Eng Mgr, Nuc Safety, Proj Eng)	5, 3, 2, or 1

OSB Evaluation

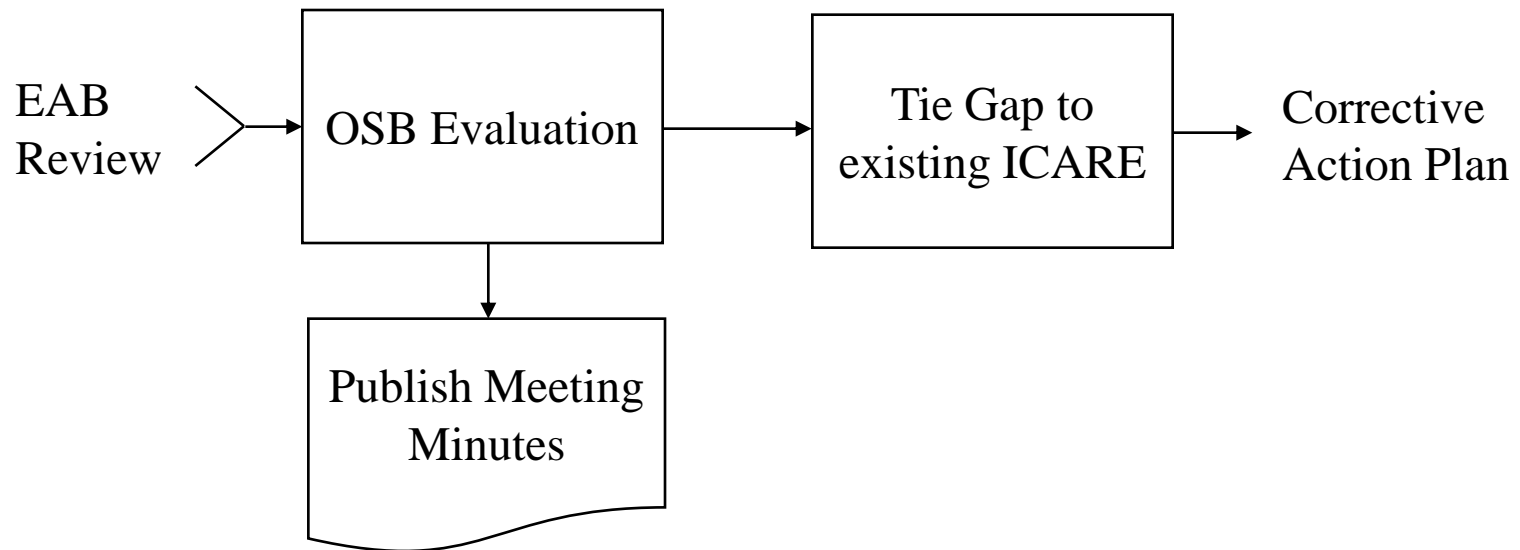

Corrective Action Plan

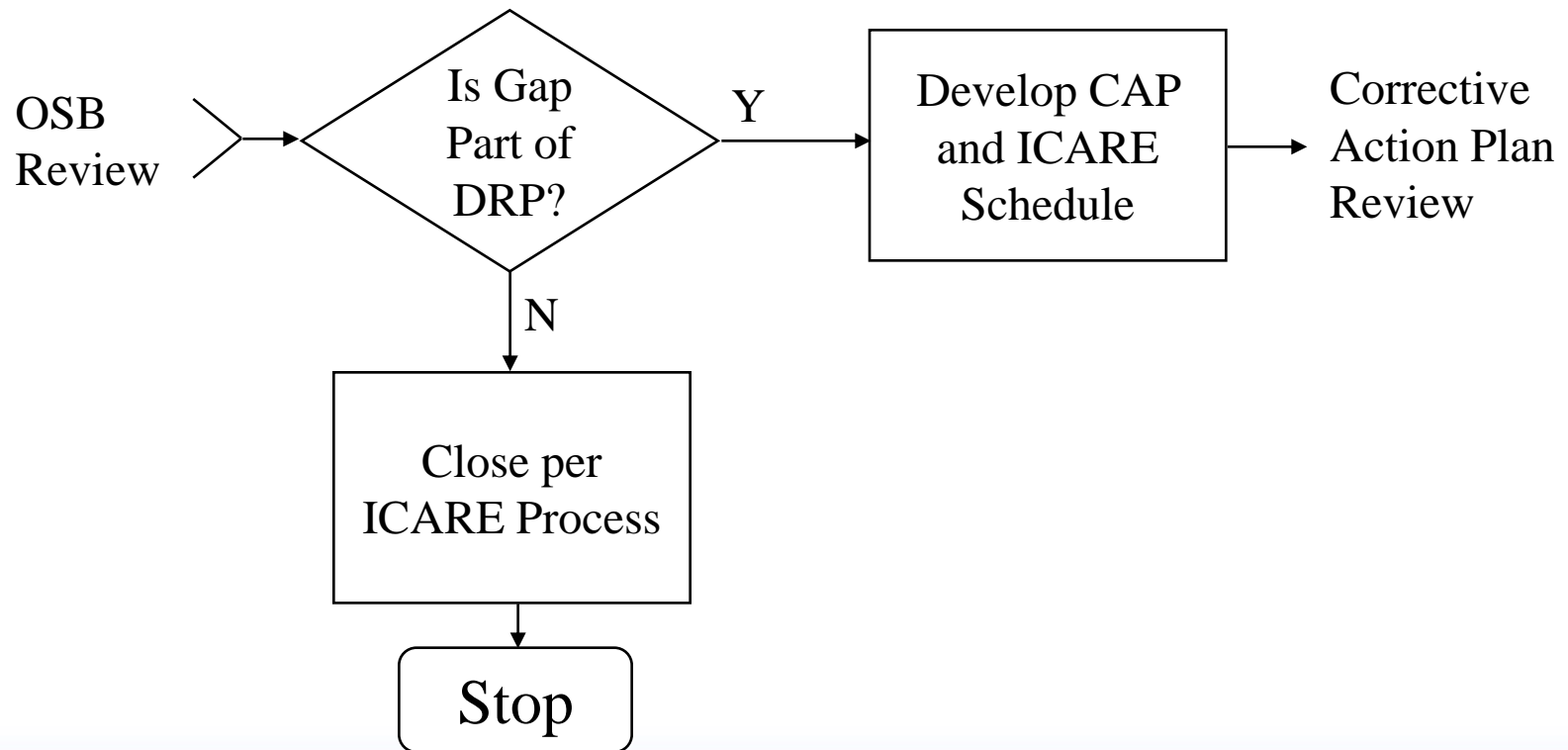

Corrective Action Plan Review

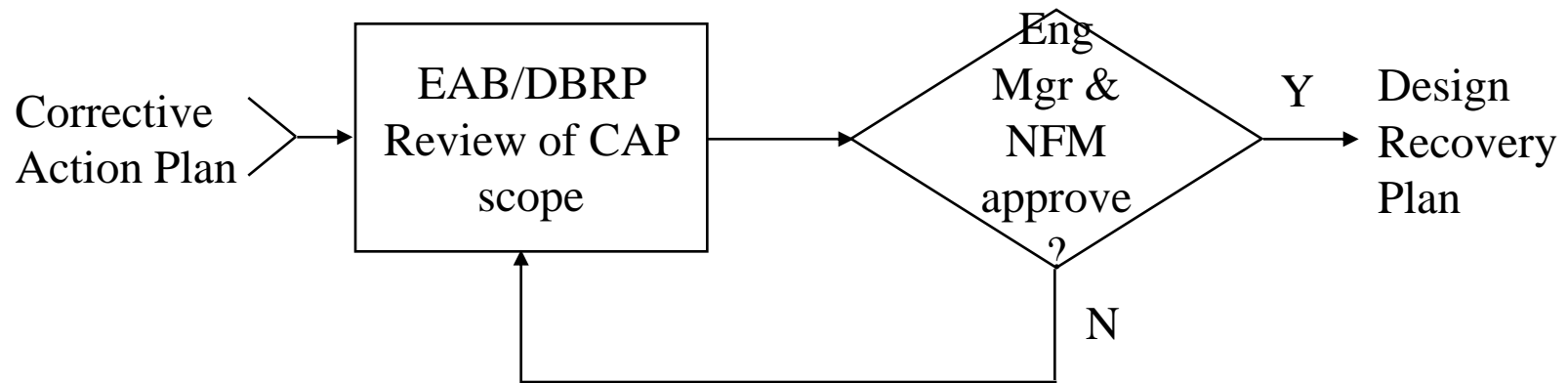

Design Recovery Plan

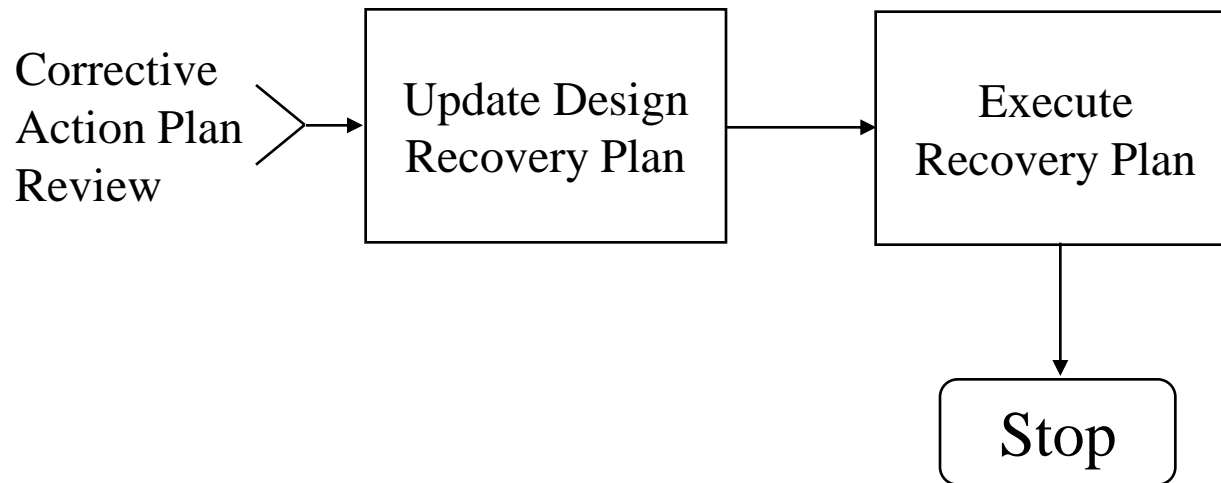

Issue Resolution Process

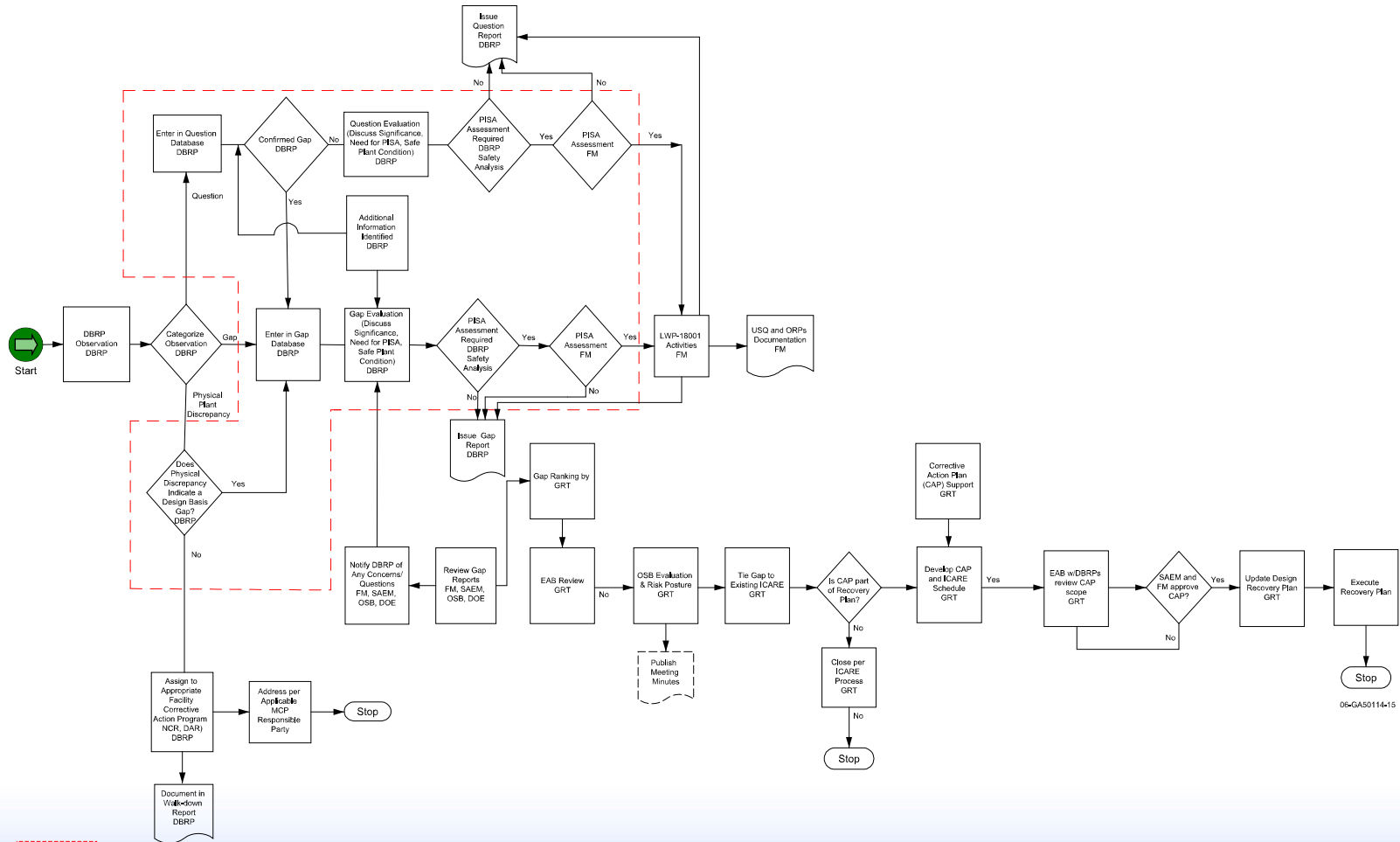

06-GAS0114-15

PISA Process

Lessons Learned

- **Issue Resolution Process (IRP) has provided timely USQ determinations**
- **IRP has increased visibility of identified issues and helped ensure an appropriate level of attention**
- **IRP is manpower-intensive**
- **Interface with ATR Engineering could be improved**
- **Knowledgeable personnel need to be continuously involved due to frequent PISA assessments and USQ determinations**

Summary

- **Design Basis Reconstitution Project at the ATR**
- **The Issue Resolution Process**
- **Lessons Learned to Date**

Questions?

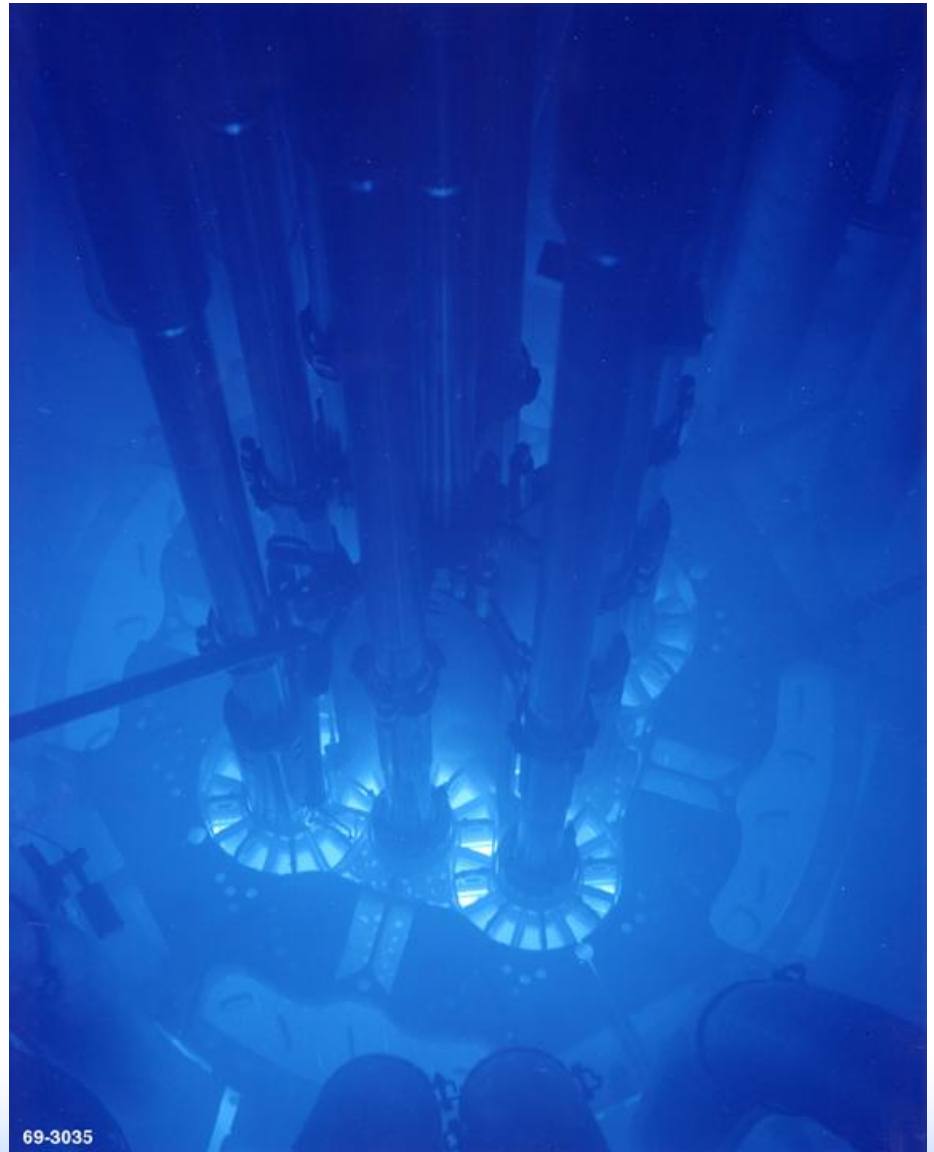

69-3035